

Techno **CNC** Systems

8 Amp Servo Pro Series[®] CNC Controller Hardware Guide



Techno CNC Systems, LLC.

29 Trade Zone Drive

Ronkonkoma, NY 11779

Phone (631) 648-7481 ♦ Fax (631) 983-4701

www.technocnc.com

Revised 4/13/2015

© 1998-2010 WPI, Inc.

Table of Contents

1. GETTING STARTED	6
ABOUT THIS MANUAL.....	6
TURNING OFF THE CONTROLLER	6
SAFETY AND USAGE GUIDELINES.....	7
2. SERVO CNC CONTROLLER.....	8
FRONT PANEL.....	8
REAR PANEL	9
3. SYSTEM CONNECTIONS	14
4. REMOVING THE TOP COVER.....	15
5. SIGNAL GENERATOR	16
INPUT	16
OUTPUT.....	17
JUMPER SETTINGS	19
JP83 – DB to USB Ground	19
JP84/JP85 – Input Power Select.....	19
JP 86 – USB to Chassis Ground.....	21
JP 87 – Internal Signal to Chassis Ground.....	21
INTERNAL CONNECTIONS	21
JP30 – Auxiliary Inputs	22
JP31 – Status LEDs	23
JP32 – Bus Expansion	23
JP33 – Step & Direction.....	23
JP40 – Input Aux Header.....	24
JP50 – Output Aux Header.....	24
JP80 – Rear Panel Power.....	25
JP81 – Rear Panel Fuse	25
JP82 – Front Panel Switch	25
AXIS PLUG-IN INTERFACES	25
6. TECHNO SOFTWARE SETTINGS.....	27
7. RESETTING YOUR SERVO DRIVE.....	29
8. UPGRADING A SERVO DRIVER.....	30
9. SERVO GAIN SETTINGS	33
To INSTALL DCN:.....	33
To USE DCN:.....	33
<i>Optimizing your Servo Settings:</i>	36
10. MOTOR WIRING:.....	38
11. POWER BOARD.....	39
12. SUPPORT:	42
13. APPENDIX.....	43
SERVO PARAMETERS.....	43
<i>PID Servo Control</i>	43
SERVO SCHEMATICS.....	47
<i>Signal Name</i>	49
SIGNAL GENERATOR WIRING DIAGRAMS.....	53
<i>Typical Output Line Circuit</i>	53

<i>Typical Input Line Circuit – Internal Power</i>	54
<i>Typical Input Line Circuit – External Power</i>	55
SIGNAL GENERATOR BOARD LAYOUT	57
CONNECTOR PIN-OUT TABLE.....	58
POWER	60
OUTPUTS	61
INPUTS	62
CONNECTORS	63
AXIS PLUG-IN INTERFACE.....	64
REVISION HISTORY	1

1. Getting Started

About This Manual

Techno CNC is a unique application involving hardware and software. We recommend that you read all of these instructions before using the product.

Since automated machining is potentially dangerous, please take the time to completely read through this manual and the software User's Guide to understand the operation of the electronics, software and machine before cutting a part.

Turning Off The Controller

Always turn off the CNC Controller when it is not in use.

Safety and Usage Guidelines

When running an automated machine tool, safety is of the utmost importance. For proper and safe use of the Techno CNC program and your CNC machine, the following safety guidelines must be followed:

- 1. Never let the machine tool run unattended.**
- 2. Require any person in the same room as a running machine tool to wear safety goggles, and to stay a safe distance from the machine.**
- 3. Allow only trained operators to run the machine tool. Any operator must have:**

Knowledge of machine tool operation.

Knowledge of personal computer operation.

Knowledge of Microsoft Windows.

Good common sense.

- 4. Place safety guards around the machine to prevent injury from flying objects. It is highly recommended that you build a safety shield around the entire tool envelope.**
- 5. Never place any part of your body within the tool envelope while the machine is online, since unexpected machine movement can occur at any time.**
- 6. Always keep the tool envelope tidy and free of any loose objects.**
- 7. Be on alert for computer crashes at all times.**

Techno CNC Systems, LLC. is not responsible for the safe installation and use of this product. You and only you are responsible for the safety of yourself and others during the operation of your CNC machine tool. Techno CNC supplies this product but has no control over how it is installed or used. Always be careful!

Techno CNC Systems, LLC. or its affiliates are not responsible for damage to any equipment or workpiece resulting from use of this product.

If you do not understand and agree with all of the above safety guidelines, do not use this product.

2. Servo CNC Controller

Front Panel



The front panel of the CNC controller has the power switch, the fan and 7 LED's with the following functions:

AXIS LED's 1, 2, 3, 4, 5 – Turns green when the respective axis is moving.

USB LED– Turns yellow when connected to the host PC USB port.

POWER LED– Turns green when the power switch is turned on.

POWER SWITCH – Turns the unit on and off. “I” is on and “O” is off. If there is ever a communications error while running Techno CNC, turn the switch off and on to reset the internal microprocessor.

Rear Panel

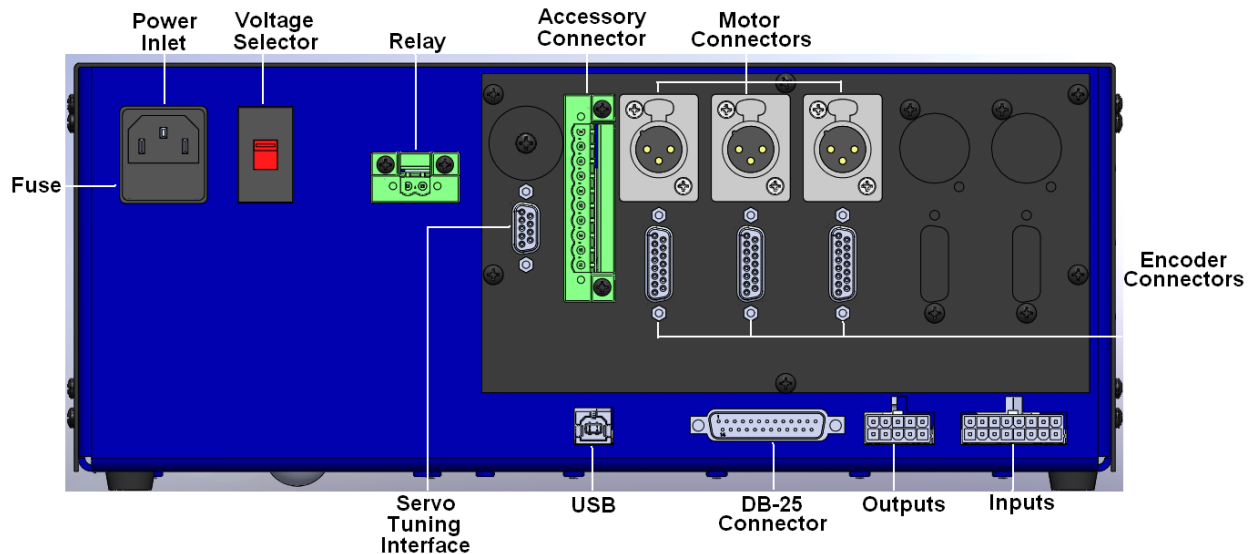

The rear panel has connectors for input and output signals as described below.

POWER INLET – Receptacle for the power supply. The unit is shipped with a standard grounded power cable for use with a 115VAC wall outlet.

USB – USB connector for communication with the USB port on the host PC. Use a USB-A to B cable with a maximum length of 3 meters to make the connection. For the most robust communication, plug the cable directly into PC, as opposed to a USB repeater or a hub. If the Techno software loses communication with the Signal Generator, electrical noise may be the cause. To reduce electrical noise problems, try using a shorter USB cable, or attach one or more ferrite chokes to the USB cable. Toroid-shaped chokes are more effective than snap-on cylindrical chokes. If you need more than 3m of USB cable length, you can use an active extension cable which comes in 4.5m lengths. Note that when running an active extension cable, the USB will run in Full Speed mode.

INPUT – The connector for up to 8 input lines. The most common use of the input lines is for limit or safety switches. These lines are all TTL- and CMOS-compatible optically isolated inputs. When a switch is open, its input signal is high (+5V). When the switch is closed, its input signal is grounded low (0V). If you need more than 8 input lines, an I/O extension board is available.

OUTPUT – The connector for up to 8 output lines. These lines are all compatible with TTL/CMOS level outputs. The Output ports are not setup to drive a 24V external system unless it accepts TTL/CMOS levels. They are all driven by HCT family logic. Output logic high is normally 5V and can go down to 3.9V at full load. Output logic low is normally 0V and can go up to 0.3V at full load. Each of these signals can provide up to 20mA of current. If you need more than 8 output lines, an I/O extension board is available.

FUSE – In this drawer is a 250V/ 10Amp slow blow fuse. If you have chronic fuse problems, please call Techno CNC or your distributor for assistance.

ACCESSORY CONNECTOR – The accessory connector creates an interface to utilize the functionality of the emergency stop circuit, 24 VDC out, the reset circuit, and two motor brakes. The pin out can be seen below.

Pin	Function
10	Reset -
9	Reset +
8	Brake 2 -
7	Brake 2 +
6	Brake 1 -
5	Brake 1 +
4	24 VDC -
3	24 VDC +
2	Emergency Stop -
1	Emergency Stop +

115-230 VAC SELECTION SWITCH– This switch allows you to use an external power source of 115 or 230 VAC. If your building is wired for 230VAC, then simply flip the switch with a flat-head screwdriver so that “230V” is clearly visible. If your building is wired for 115 VAC, then flip the switch until “115V” is clearly visible. **Note that severe damage can occur if you have 115 selected and your building is wired for 230VAC.**

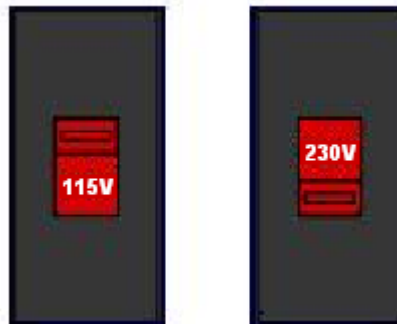

DB-25 CONNECTOR FOR MOTOR SIGNALS – This uses a DB-25 Cable to send step and direction signals from the Techno CNC Signal Generator to an additional external drive box. The pin assignments are as follows:

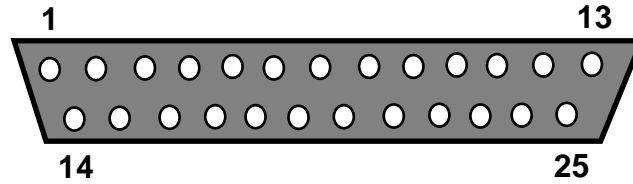

DB25 Pin No.	Signal	DB25 Pin No.	Signal
1	OUTPUT 1	14	ENABLE ALL
2	OUTPUT 2	15	INPUT 1
3	STEP AXIS 5	16	INPUT 2
4	DIRECTION AXIS 5	17	INPUT 3
5	INPUT 5	18	INPUT 4
6	INPUT 6	19	DIRECTION AXIS 4
7	INPUT 7	20	DIRECTION AXIS 3
8	INPUT 8	21	DIRECTION AXIS 2
9	DIRECTION AXIS 1	22	Internal VCC +5V
10	STEP AXIS 4	23	OPT VCC (INPUT)
11	STEP AXIS 3	24	Internal GND
12	STEP AXIS 2	25	OPT GND (INPUT)
13	STEP AXIS 1		

POWER CONNECTOR TO MOTORS – The motors for axes 1-5 plug into these connectors. The motor lines 1-5 are correlated to any combination of the X, Y, Z, A and/or B axes in the Motor Signal Setup menu in the Techno CNC software. A axis cover plate is installed on any unused motor connector for units with less than 5 axes. Each motor connector is a Neutrik XLR 3 Pin Receptacle (See Section on Motor Cabling for Mating Connector Information). The pin assignments for the Motor Connector are as follows (looking from the rear of the unit):

XLR Pin	Wire
1	R
2	S
3	T

ENCODER CONNECTOR TO MOTORS – The encoders for axes 1-5 plug into these connectors. Each encoder connector is a NorComp DB-15 female connector. The pin assignments for the Encoder Connector are as follows.

DB-15 Pin	Wire
1	HALL S2
2	ENC VCC
3	HALL S3
4	B (-)
5	A (-)
6	N/C
7	LIM (-) (Opt.)
8	GND (Opt.)
9	HALL S1
10	ENC GND
11	Z (+)
12	B (+)
13	A (+)
14	N/C
15	LIM (+) (Opt.)

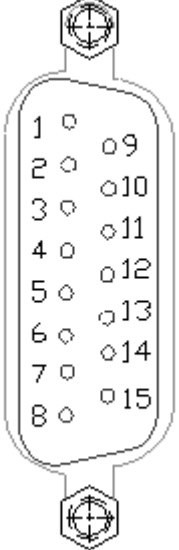

Optional limit switch connection through the encoder cable.

SERVO TUNING PORT – This port allows the communication of the drive modules with a PC. The DB-9 female connector plugs into the serial port on your PC. The drive parameters can then be modified using the DCN software included with your Techno CNC installation. If you do not have a serial port on your PC a serial to USB converter will work for this application. For more information on tuning see “Servo Grain Settings” later in this manual.

Never connect or disconnect motor cables while the power is on. This will result in damage to the driver box.

The mating motor cable connector is a Neutrik XLR 3-pin male connector part # NC3MX. The mating encoder cable connector is a NorComp DB-15 male connector part # 172-E15-103R001 Please see the section on Servo Motor Cabling later in this manual for more information.

3. System Connections

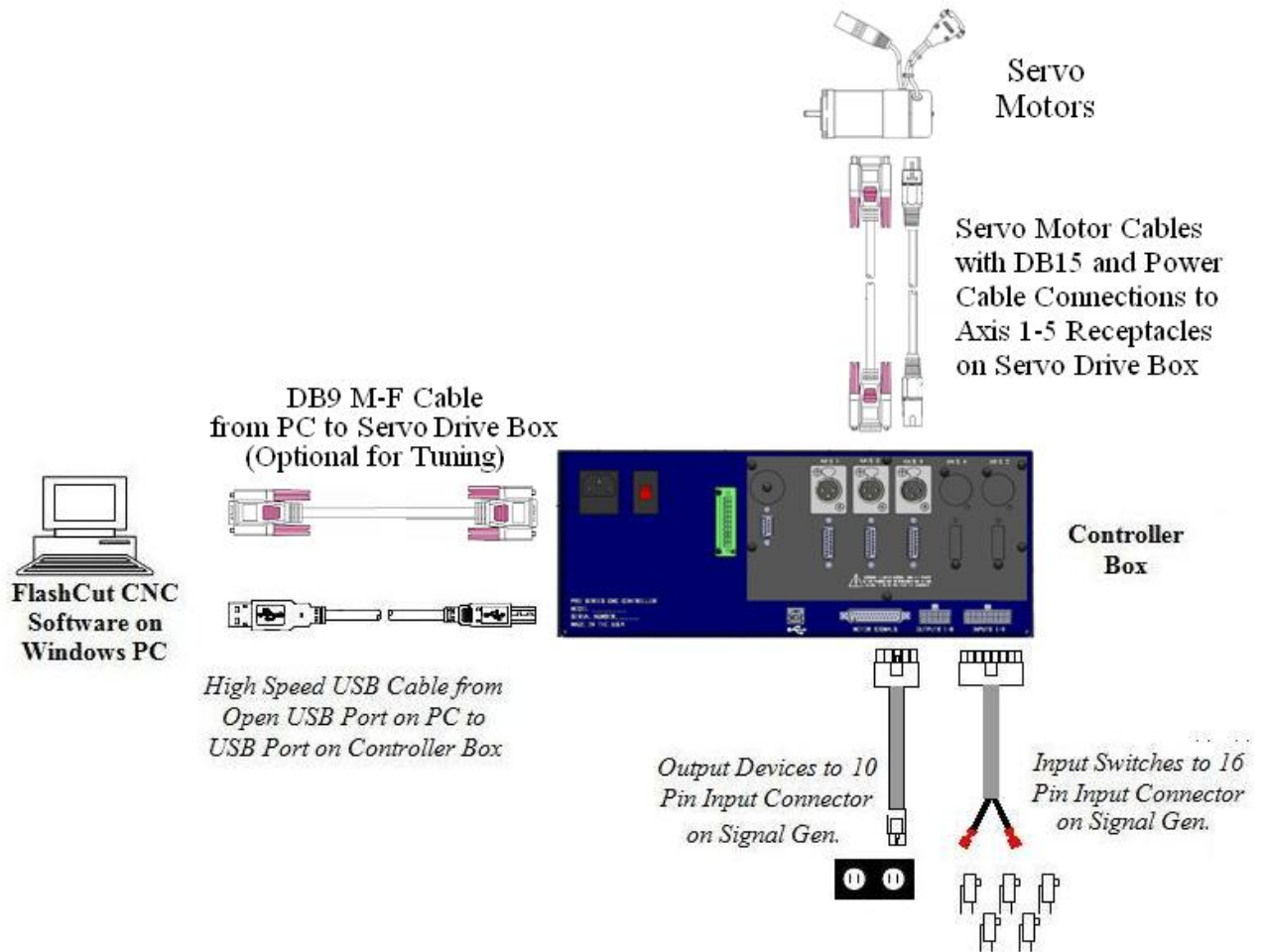

4. Removing the Top Cover

To remove the cover from the unit remove the 8 total screws located on the left and right sides of the unit. There are 4 screws on either side. Then lift the top cover off.



5. Signal Generator

Input

The default setting for each of the input lines is normally closed (NC). The input line settings can be individually changed between normally closed (NC) or normally open (NO) input lines using Techno CNC software. Please refer to the Techno CNC User's Guide under "Input Line Settings" for further information.

In the Techno CNC software, the Input Line Status dialog displays "OPEN" for a high-level input voltage, or open switch, and "CLOSED" for a low-level input voltage or closed switch.

The input lines are all optically isolated. Jumpers J84 and J85 enable you to choose between the internal power of the Signal Generator and isolated power from an external source. Both jumpers must be set on the same pair of pins (either both must be on pins 1 and 2 or both must be on pins 2 and 3).

Internal Power- This is the most convenient option and works well for most applications, but negates some of the signal isolation. When JP84 shorts pins 1 and 2, OPT VCC gets its power from the Internal 5V power source. When JP85 shorts pins 1 and 2, OPT GND is directly connected to the Internal GND.

External Isolated Power

For the best noise immunity, connect an external 5V-24V power supply to the LED side of the optical couplers. When JP84 shorts pins 2 and 3, OPT VCC gets its optically isolated power from the TB-VCC. When JP85 shorts pins 2 and 3, OPT GND is directly connected to the TB-GND.

Choose **only one** of the following methods to supply power:

1. Connect a power source to the TB 40 screw terminal.
2. Connect a power source through pins 23 and 25 of the DB-25 connector.

If you are providing an external voltage through pins 23 and 25 of the DB25 Motor Signal connector or via TB-40, then you must have both JP84 and JP85 jump pins 2 and 3, OTHERWISE SEVERE DAMAGE COULD RESULT.

BE VERY CAREFUL WHEN DOING ANY WIRING. IMPROPER WIRING WILL DAMAGE THE SIGNAL GENERATOR.

Input lines 1, 2, 3 & 4 are also connected through pins 15, 16, 17 & 18 respectively of the Motor Signal connector, and input lines 5, 6, 7 & 8 are also connected through pins 5, 6, 7 & 8 respectively of the Motor Signal connector. This makes it convenient to send any signals from an external motor driver box, such as limit lines or servo position error signal, back to the Signal Generator through the DB25 cable without

using a separate input cable. Note that if an input line is being used through the Motor Signal connector, that line must remain open in the Input connector.

The receptacle that plugs into this connector is a Molex-Waldom Mini-Fit Jr. Series 16 pin receptacle (part number 39-01-2160), with female pins (part number 39-00-0039 or 39-00-0047 for 22 gauge or thinner wires).

The Molex 63811-1000 for 14-24 AWG universal or Molex 11-01-0197 Crimp Tools are recommended for installing the pins. Kits containing connectors and pins are available through Techno CNC or an electronics distributor.

The input lines as seen from the back of the box are arranged as follows (all connections denoted by “OPT-GND” are optically isolated ground.):

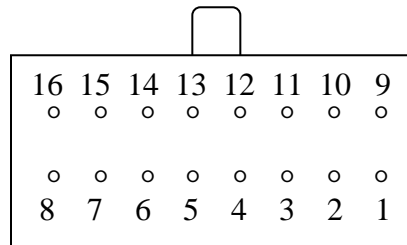

Mini-Fit Jr. Pin No.	Signal	Mini-Fit Jr. Pin No.	Signal
1	OPT-GND	9	INPUT 1
2	OPT-GND	10	INPUT 2
3	OPT-GND	11	INPUT 3
4	OPT-GND	12	INPUT 4
5	OPT-GND	13	INPUT 5
6	OPT-GND	14	INPUT 6
7	OPT-GND	15	INPUT 7
8	OPT-GND	16	INPUT 8

Output

This connector is for up to 8 output lines. These lines are all compatible with TTL/CMOS level outputs. The Output ports are not setup to drive a 24V external system unless it accepts TTL/CMOS levels. They are all driven by HCT family logic. Output logic high is normally 5V and can go down to 3.9V at full load. Output logic low is normally 0V and can go up to 0.3V at full load. Each of these signals can provide up to 20mA of current.

Two additional pins on this connector are provided for your output lines: ground and +5V. These are connected to GND and +5V and are not optically isolated. This 5V circuit can source up to 100 mA. Any larger current demand would require a larger power source.

BE VERY CAREFUL WHEN DOING ANY WIRING. IMPROPER WIRING WILL DAMAGE THE SIGNAL GENERATOR.

The output lines are all initialized to low (0V) when you turn on the Signal Generator. Output lines 1 and 2 are also connected through pins 1 and 2 respectively of the Motor Signal connector. This makes it convenient to connect up to 2 output signals to an external motor driver box to drive devices such as solid-state relays that might be in an external motor driver box.

The receptacle that plugs into this connector is a Molex-Waldom Mini-Fit Jr. Series 10 pin receptacle (part number 39-01-2100), with female pins (part number 39-00-0039 or 39-00-0047 for 22 gauge or thinner wires).

The Molex 63811-1000 for 14-24 AWG universal or Molex 11-01-0197 Crimp Tools are recommended for installing the pins. Kits containing connectors and pins are available through Techno CNC or an electronics distributor.

The output lines as seen from the back of the box are arranged as follows:

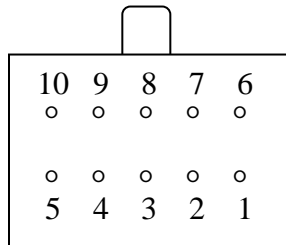

Mini-Fit Jr. Pin No.	Signal	Mini-Fit Jr. Pin No.	Signal
1	OUTPUT 1	6	OUTPUT 2
2	OUTPUT 3	7	OUTPUT 4
3	OUTPUT 5	8	OUTPUT 6
4	OUTPUT 7	9	OUTPUT 8
5	+5V	10	GROUND

Jumper Settings

Pin 1 of all jumpers is indicated by a small white dot printed on the PCB.

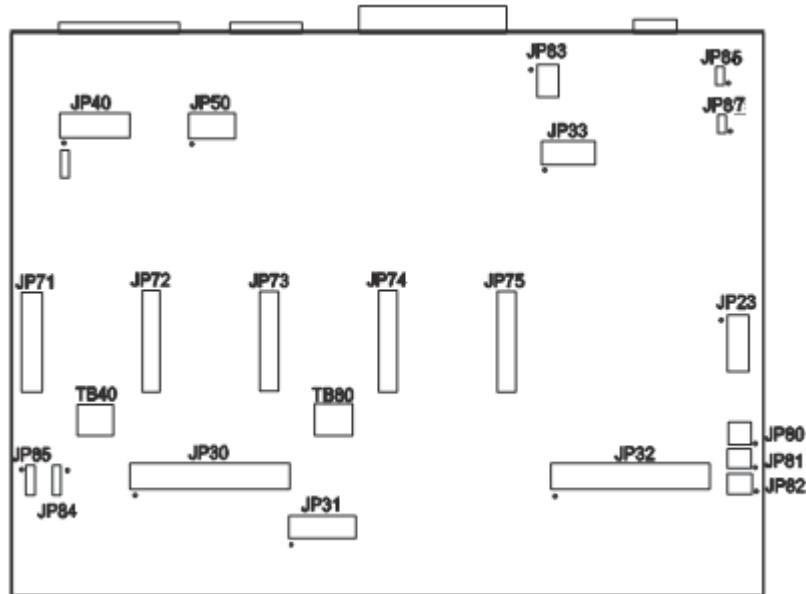

JP83 – DB to USB Ground

This connects the DB 25 ground to the USB ground. By default pins 1 and 2, 3 and 4, and 5 and 6 are jumped as pairs. In order to isolate only the USB shield only jumper pins 3 and 5 as well as removing JP 86. In order to isolate only the chassis jumper pins 1 and 2, 3 and 5, and 4 and 6 as well as removing JP 86 and JP 87.

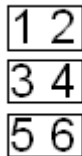

JP84/JP85 – Input Power Select

These two jumpers enable you to choose between the internal power of the Signal Generator and isolated power from an external source. Both jumpers must be set on the same pair of pins (either both must be on pins 1 and 2 or both must be on pins 2 and 3).

Internal Power

This is the most convenient option and works well for most applications, but negates some of the signal isolation. When JP84 shorts pins 1 and 2, OPT VCC gets its power from the Internal 5V power source. When JP85 shorts pins 1 and 2, OPT GND is directly connected to the Internal GND.

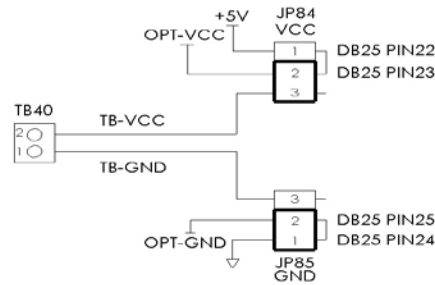

External Isolated Power

For the best noise immunity, connect an external 5V-24V power supply to the LED side of the optical couplers. When JP84 shorts pins 2 and 3, OPT VCC gets its optically isolated power from the TB-VCC. When JP85 shorts pins 2 and 3, OPT GND is directly connected to the TB-GND.

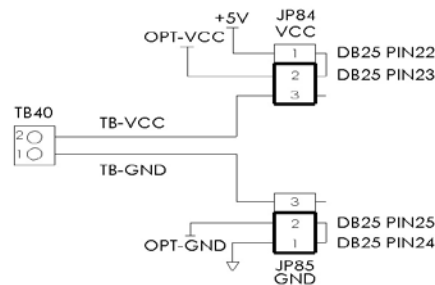

Choose **only one** of the following methods to supply power:

1. Connect a power source to the TB 40 screw terminal.
2. Connect a power source through pins 23 and 25 of the DB-25 connector.
3. Check the resistor value in RP41 to make sure it matches the voltage in TB40.

TB40 Voltage	RP41 Value (10 pin 9 Resistor SIP)
5V	3.9k Ω (Default)
12V	11k Ω
24V	22k Ω

If you are providing an external voltage through pins 23 and 25 of the DB25 Motor Signal connector or via TB-40, then you must have both JP84

and JP85 jump pins 2 and 3, OTHERWISE SEVERE DAMAGE COULD OCCUR.

JP 86 – USB to Chassis Ground

This jumper connects the USB shield to the chassis ground of the Signal Generator when jumped. In order to isolate the USB shield remove this jumper and make sure only pins 3 and 5 are jumper on JP 83. In order to isolate the DB 25 shield and the USB shield remove this jumper. In order to isolate the DB 25 shield, the USB shield, and the chassis remove this jumper as well as JP87.

JP 87 – Internal Signal to Chassis Ground

This jumper connects the internal signal ground to the chassis ground of the Signal Generator when jumped. In order to isolate the chassis ground remove this jumper in addition to JP 86 as well as jumping pin 3 and 5, and 4 and 6 on JP 83. In order to isolate the DB 25 shield, the USB shield, and the chassis remove this jumper as well as JP86.

Internal Connections

The diagram below shows the locations of the internal connectors. The top of the diagram corresponds to the back side of the signal generator (where the external connectors are located). The small dot next to some of the connectors designates the number 1 pin position.

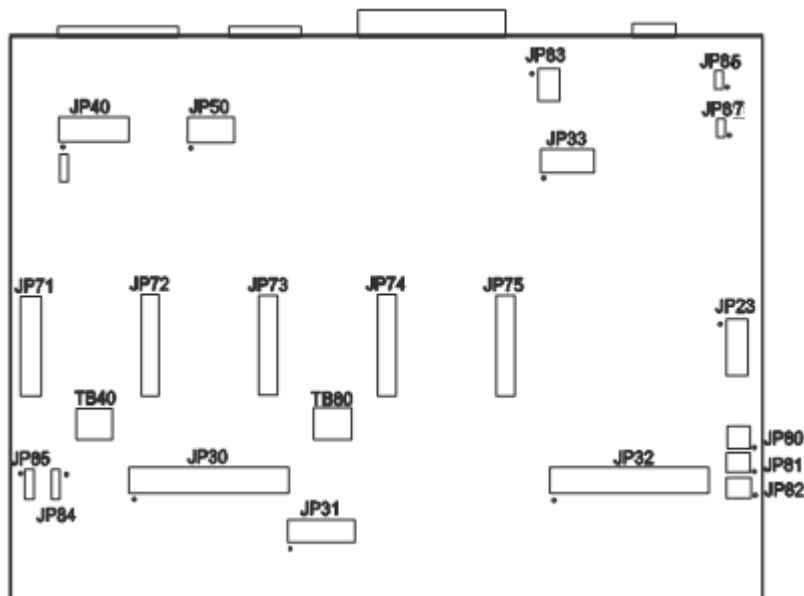

On the following diagrams, the positions of the connectors will be highlighted in black.

Connectors JP30, JP31, JP32, JP33

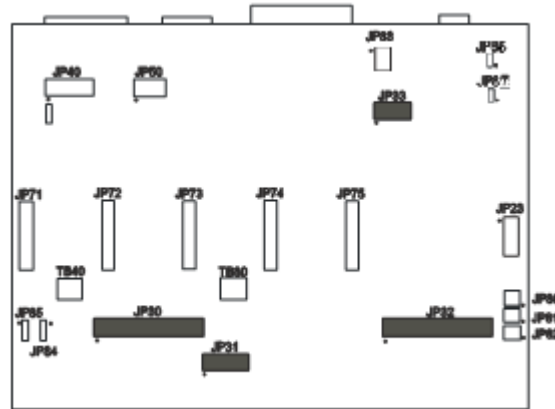

JP30 – Auxiliary Inputs

This contains all of the Input Signals 1-8 which come out of the 501A board and Input Signals 9-32 which come out of the I/O Expansion board.	+3.3V	1	2	+3.3V
	GPI32	3	4	GPI1
	GPI31	5	6	GPI2
	GPI30	7	8	GPI3
	GPI29	9	10	GPI4
	GPI28	11	12	GPI5
	GPI27	13	14	GPI6
	GPI26	15	16	GPI7
	GPI25	17	18	GPI8
	GND	19	20	GND
	GPI24	21	22	GPI9
	GPI23	23	24	GPI10
	GPI22	25	26	GPI11
	GPI21	27	28	GPI12
	GPI20	29	30	GPI13
	GPI19	31	32	GPI14
	GPI18	33	34	GPI15
	GPI17	35	36	GPI16
	+3.3V	37	38	+3.3V
	GND	39	40	GND

JP31 – Status LEDs

This is for connecting wired LEDs from a custom chassis to the 501A LED signals.	+5V	1	2	N/C
	LED-DIR1	3	4	LED-STEP1
	LED-DIR2	5	6	LED-STEP2
	LED-DIR3	7	8	LED-STEP3
	LED-DIR4	9	10	LED-STEP4
	LED-DIR5	11	12	LED-STEP5
	LED-AUX	13	14	LED-USB
	GND	15	16	LED-PWR

JP32 – Bus Expansion

This contains signal and address lines for the I/O Expansion board.	+3.3V	1	2	GND
	CS6	3	4	STATUS6
	TXD2	5	6	FAULT6
	RXD2	7	8	AUX1-STB
	OUT-ENA	9	10	AUX2-STB
	OUT2-STB	11	12	OUT1-STB
	OUT4-STB	13	14	OUT3-STB
	+5V	15	16	+5V
	GND	17	18	GND
	A0	19	20	A1
	DATA1	21	22	DATA2
	DATA3	23	24	DATA4
	DATA8	25	26	DATA7
	DATA6	27	28	DATA5
	+7V	29	30	+7V
	SPHOME	31	32	ENC CLK
	+3.3V	33	34	ENC DIR
	AGND	35	36	AV+
	DAC2	37	38	DAC1
	ADC1	39	40	AGND

JP33 – Step & Direction

This contains all of the step and direction signals for 5 axes of motion.	STEP5	1	2	ENA
	STEP4	3	4	DIR5
	STEP3	5	6	DIR4
	STEP2	7	8	DIR3
	STEP1	9	10	DIR2
	GND	11	12	DIR1

Connectors JP40, JP50

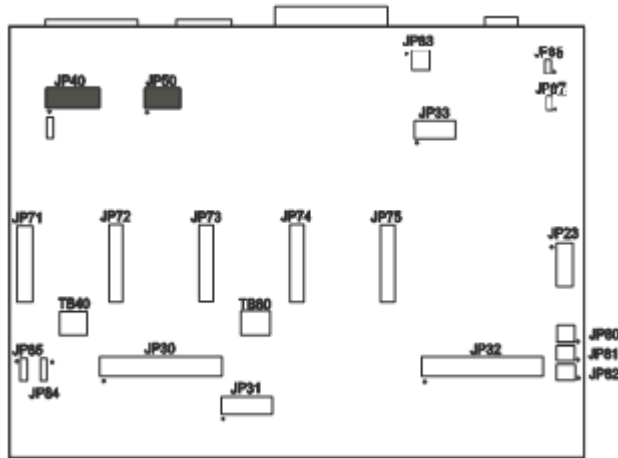

JP40 – Input Aux Header

<p>This contains the same signals as the Mini-Fit Jr. Input Connector. It is provided for the convenience of using a different input connector or an external input connector on a custom chassis.</p>	GPI1	1	2	OPT-GND
	GPI2	3	4	OPT-GND
	GPI3	5	6	OPT-GND
	GPI4	7	8	OPT-GND
	GPI5	9	10	OPT-GND
	GPI6	11	12	OPT-GND
	GPI7	13	14	OPT-GND
	GPI8	15	16	OPT-GND

JP50 – Output Aux Header

<p>This contains the same signals as the Mini-Fit Jr. Input Connector. It is provided for the convenience of using a different input connector or an external input connector on a custom chassis.</p>	GPO2	1	2	GPO1
	GPO4	3	4	GPO3
	GPO6	5	6	GPO5
	GPO8	7	8	GPO7
	GND	9	10	VCC

Connectors JP80, JP81, JP82

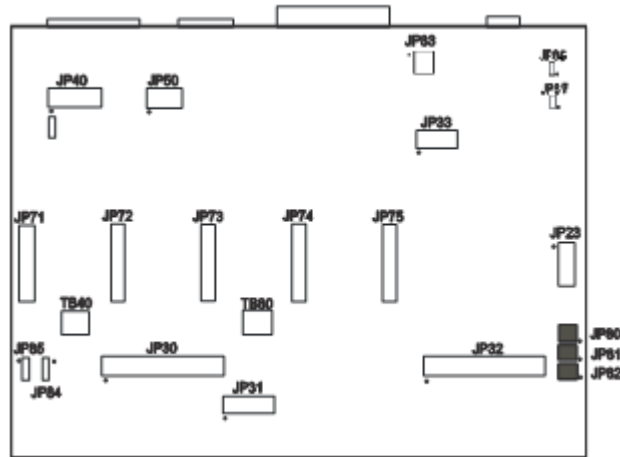

JP80 – Rear Panel Power

Connect the main power here. It can be 8.5V – 16V DC or AC. See current draw chart for power requirements.

JP81 – Rear Panel Fuse

This is for an optional power fuse. The unit is shipped with a shunt instead of a fuse. If you replace the shunt with a fuse, it should be sized according to your power requirements.

JP82 – Front Panel Switch

Connect the main power switch here.

Axis Plug-In Interfaces

Axis Plug-Ins JP71 – JP75

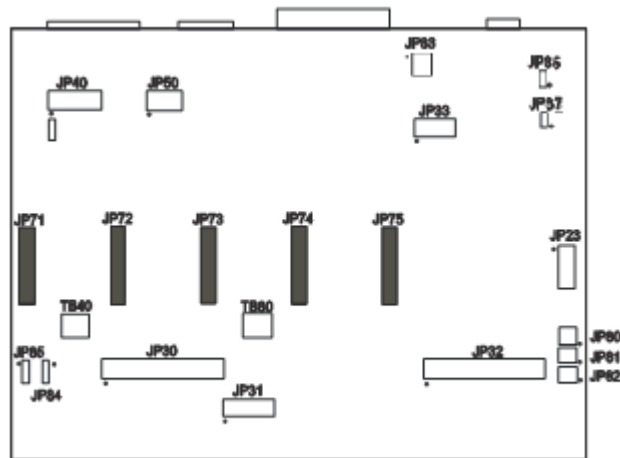

The Axis plug-in interfaces are used to add additional functions to the main signal generator board. For example, a stepper drive plug-in card or cable will enable you to drive a stepper motor directly from the signal generator box.

1	2
3	4
5	6
7	8
9	10
11	12
13	14
15	16
17	18
19	20

Each of these plug-in cards is a SKT10X2 connector, with the pin configuration on the left. Pin numbers 1-5, 7, 13, 15 and 17-20 perform the same function on each jumper.

Per the chart below, pins 6, 8-12, 14 and 16 have different values of Status, Fault, InputA, Dir, InputB, Step, SCOM and CS respectively for each plug-in card.

Pin No.	Label	Function	JP-71	JP-72	JP-73	JP-74	JP-75
1	HV-PWR	High Voltage Power	HV-PWR	HV-PWR	HV-PWR	HV-PWR	HV-PWR
2	HV-PWR	High Voltage Power	HV-PWR	HV-PWR	HV-PWR	HV-PWR	HV-PWR
3	GND	Ground	GND	GND	GND	GND	GND
4	GND	Ground	GND	GND	GND	GND	GND
5	RxD2	Serial Com. Receive	RxD2	RxD2	RxD2	RxD2	RxD2
6	STATUS	Status	STATUS1	STATUS2	STATUS3	STATUS4	STATUS5
7	TxD2	Serial Com. Transmit	TxD2	TxD2	TxD2	TxD2	TxD2
8	FAULT	Fault Indicator	FAULT1	FAULT2	FAULT3	FAULT4	FAULT5
9	INPUTA	Input A	IN8	IN10	IN12	IN14	IN16
10	DR	Direction	DR1	DR2	DR3	DR4	DR5
11	INPUTB	Input B	IN9	IN11	IN13	IN15	IN17
12	ST	Step	ST1	ST2	ST3	ST4	ST5
13	SM0	SM0	SM0	SM0	SM0	SM0	SM0
14	SCOM	SCOM	SCOM1	SCOM2	SCOM3	SCOM4	SCOM5
15	SM1	SM1	SM1	SM1	SM1	SM1	SM1
16	CS	Chip Select	CS1	CS2	CS3	CS4	CS5
17	ENA	Enable	ENA	ENA	ENA	ENA	ENA
18	+5V	+5V	+5V	+5V	+5V	+5V	+5V
19	GND	GND	GND	GND	GND	GND	GND
20	GND	Ground	GND	GND	GND	GND	GND

6. Techno Software Settings

Motor Signal Setup:

In Techno CNC go to Configuration...System...Motor Signals and choose the appropriate servo box that you have:

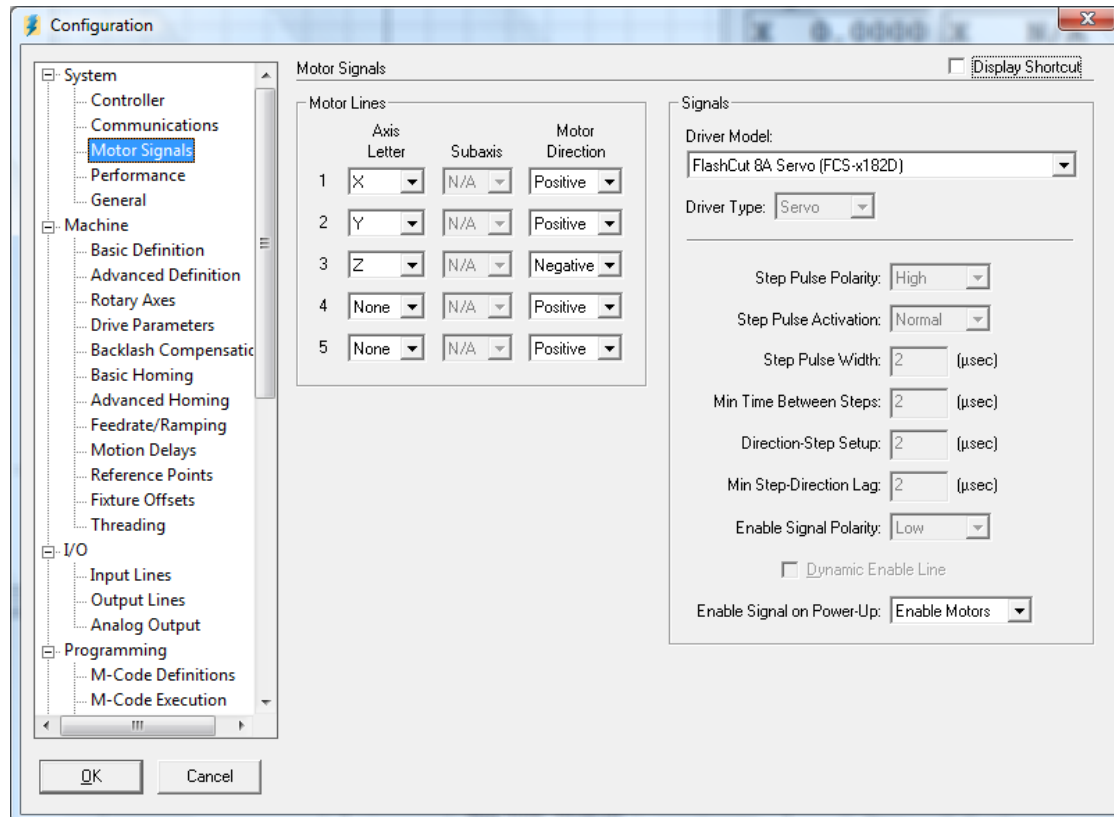

Input Lines Setup:

If you overdrive the servomotors, they will get out of position beyond their programmed tolerance. If this occurs a fault signal will be sent from the servo box to the signal generator through one of the above input lines.

This signal is automatically routed to the Signal Generator via the internal servo cables. There is no need to connect wires to lines 9, 11, 13, 15 or 17 of the input line connector on the back of the Signal Generator.

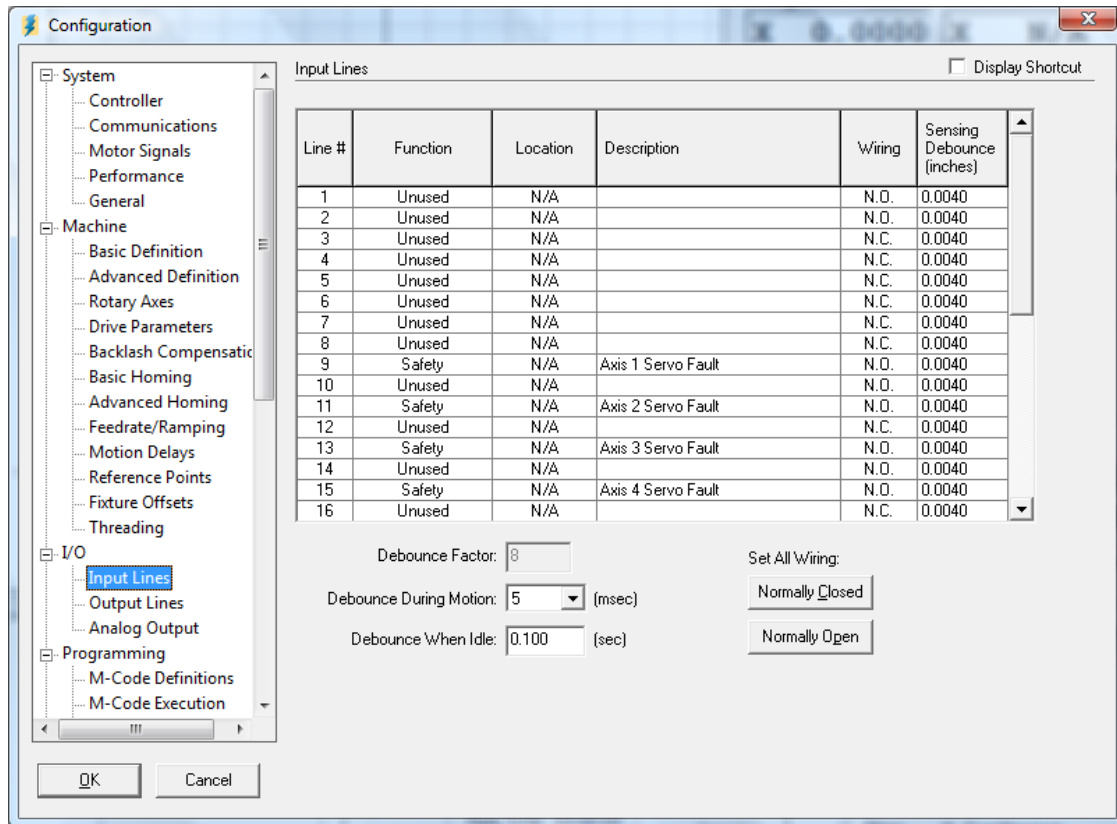

Please note that if you are using input lines, make sure to not occupy inputs 9, 11, 13, 15 or 17 as a conflict will occur and the input connected to these lines will malfunction.

7. Resetting Your Servo Drive

1. If a Servo Fault occurs you must reset the Servo Module. To reset the module, you can turn the servo drive modules off using the E-Stop button in the front, wait 30 seconds then pull the E-Stop button back out.
2. Check your feedrate/ramping settings to make sure they are not too aggressive.
3. Resume movement. You may need to re-home the axes as they have most likely lost position.

Note that a servo fault might show up by a message that says, “A limit switch has briefly been tripped and reset...” In this case the error will not show up if you check the input status.

8. Upgrading a Servo Driver

The servo box is ready to accept up to 5 servo drive modules. If you want to add a drive module or you need to replace a servo drive module, follow these instructions:

1. Remove the top cover. For more detailed instructions see “Removing the Top Cover” earlier in this manual.
2. If you are replacing a drive, carefully remove all of the cabling from the drive that you are replacing
3. Remove the two screws that fasten the bottom flange of the servo drive to the Servo Box Chassis. It is actually easiest if you remove one of the screws and loosen the other.

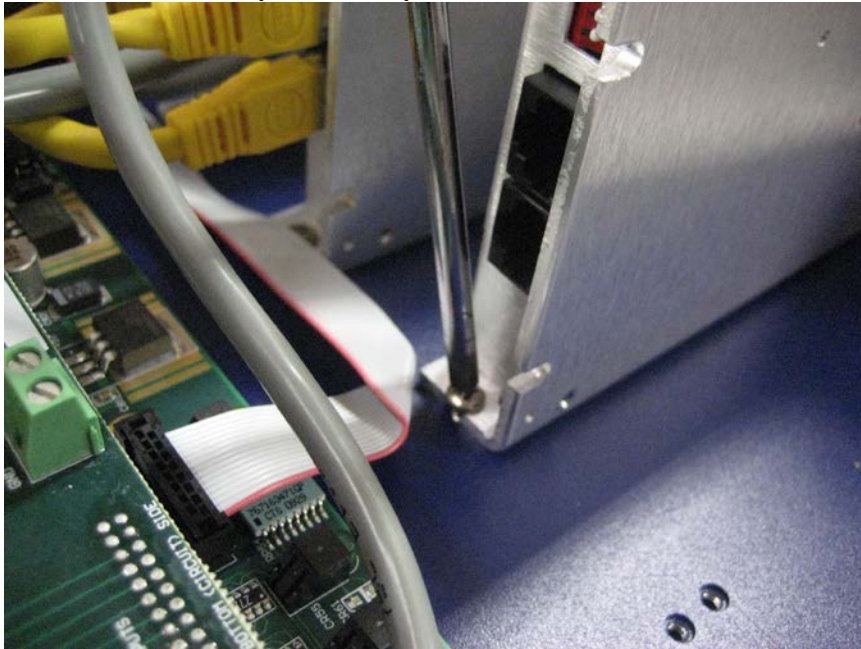

4. Remove the drive module.
5. Make sure the dip switch settings are set properly on the new drive module. Inside of the control box, there is one drive module for each axis. These modules have a set of 8 dip switches on the side next to the RJ-45 receptacles. Switches 1-6 should be towards the numbers on the switch bank (Towards the front panel of the drive module) for differential encoders. If a single ended encoder is to be used switch 2 should be in the off position. Switches 7 and 8 should be away from the numbers on the switch bank for **all of the drive modules except the last one in line**. The last drive module in line should have switches 7 and 8 towards the numbers. For example, for a 3 axis system, the switch bank in the modules for axes 1 and 2 should look like the figure on the left, while the last module (axis 3) should have switch settings like the figure on the right. In a 4 axis system, the switch bank in modules 1-3 should look like the figure on the left and module 4 should look like the figure on the right.

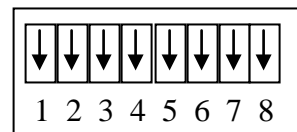
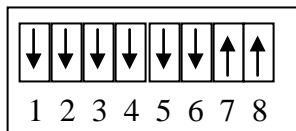

SW	Signal	Description
1	Step/Dir	On= Step/Direction Mode (Default) Off= Network Mode
2	Diff Encoder	On= Differential Encoder (Default) Off= Single Ended Encoder
3	Reserved	Reserved. Must Be On
4	Address 2	Address Select Switch 2
5	Address 1	Address Select Switch 1
6	Address 0	Address Select Switch 0
7	T-Input	Transmit Line Terminator
8	T-Output	Receive Line Terminator

6. For noise immunity, it is good to install a grounding wire from Pin 2 of CN1 to the chassis of the drive module.

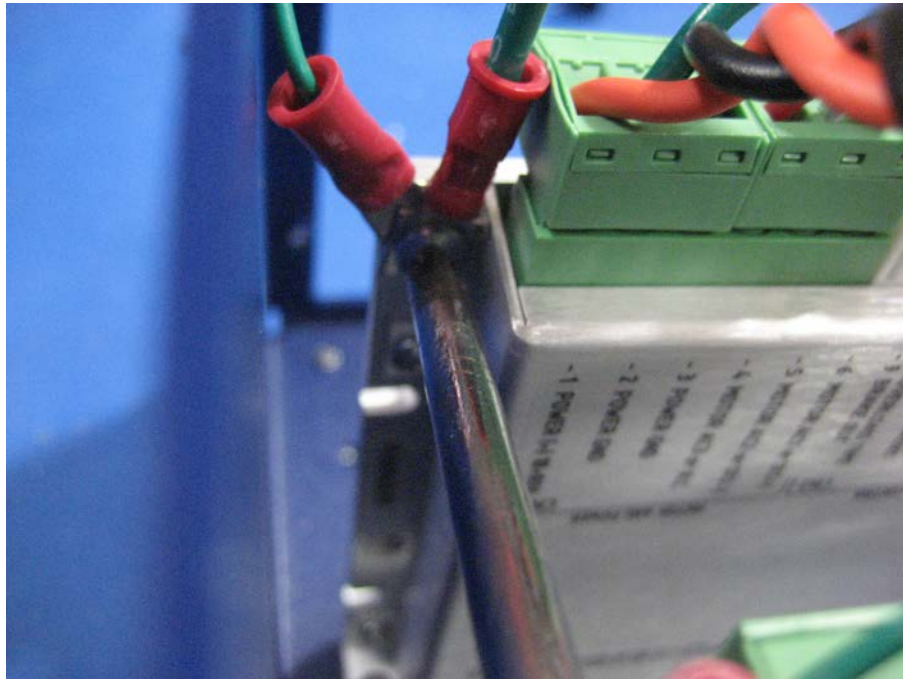

7. Install the new drive module and secure it with the two screws to the bottom of the chassis.
8. Install all of the connectors of the cabling onto the drive module.
9. There are two RJ-45 connections on the end of each drive module (CN5 and CN6). The first RJ-45 cable goes from the communications card on the main servo control box to CN6 of the first drive. The next cable goes from CN5 of the first module to CN6 of the following module. This continues up to the last drive module which only has CN6 connected from the preceding drive module.

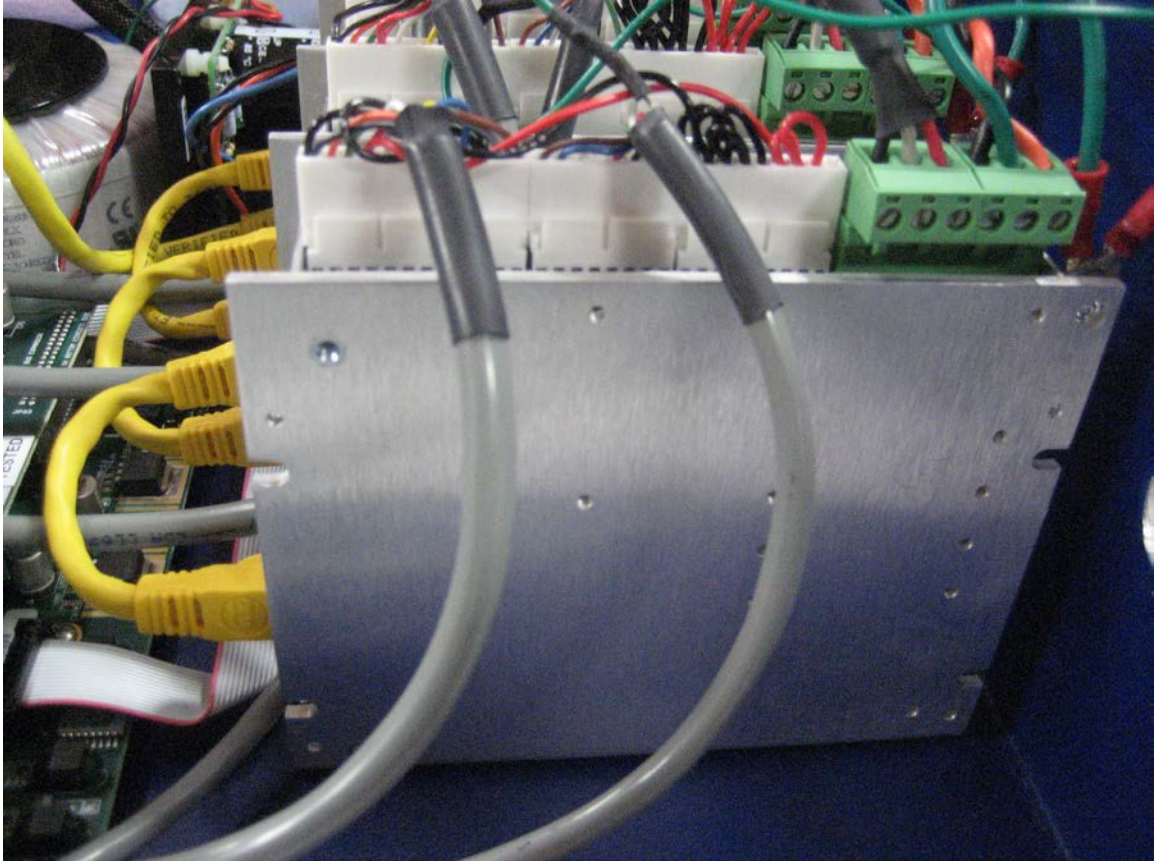

10. Do a final check on all of the connections
11. Replace the cover and the 8 screws.

9. Servo Gain Settings

There are mathematical parameters for the servo system that need to be tuned to account for the differing mechanical behavior of a given machine tool and a given motor. We have already pre-tuned these settings in your system given some assumptions that were made about the dynamics of your machine and motors. Sometimes these settings need to be adjusted for better performance. The main parameters that need to be adjusted are the Servo Gain, the Dead Band Compensation, and the Error Limit.

The Servo Gain is the stiffness of the motors. The higher the servo gain, the tighter the motor will follow the toolpath, however, the tighter the system, the more susceptible the motors will be to high frequency vibration when at rest.

The dead band compensation negates the “dead band” zone of the motors, when they have very little stiffness. The higher the dead band compensation, the smaller this zone is. However, the larger this number, the more susceptible the motors will be to high frequency vibration when at rest.

Since a servo system is a feedback system, it moves to a position, compares the actual position with the desired position, and then physically corrects itself. The amount that the actual position can differ from the desired position at any time is the Error Limit. If the Error Limit is exceeded, an error signal is sent to the signal generator, and the Servo System needs to be reset. The higher the Error Limit, the less susceptible you will be to getting a servo error.

To change these settings, we have provided a program called Distributed Control Network Facility (DCN).

To Install DCN:

1. DCN is automatically installed on your hard drive if you have Techno CNC version 3.0.6 or later. It is located by default under:

C:\Program Files\Techno CNC 3\Servo Software

2. If you do not have DCN installed, you can either find it on the Techno CNC Installation CD or on the Downloads portion of the support.technocnc.com website. Please copy the entire contents of the Servo Software folder onto your hard drive in the C:\Program Files\Techno CNC 3 directory.

To Use DCN:

1. If you are using a model 501A (USB) signal generator :

Connect the servo control box to an available serial port on your computer. If you do not have a serial port, it is OK to use an off-the shelf USB-Serial adapter that you can find at most computer stores. Make sure that Techno is connected. This will allow you to change parameters using DCN and interactively test the new parameters using Techno.

2. Launch the Program (DCN.exe) (for example, from the Start menu choose Run.. then type "C:\Techno Servo Software\DCN.exe"). A screen should appear that looks like this:

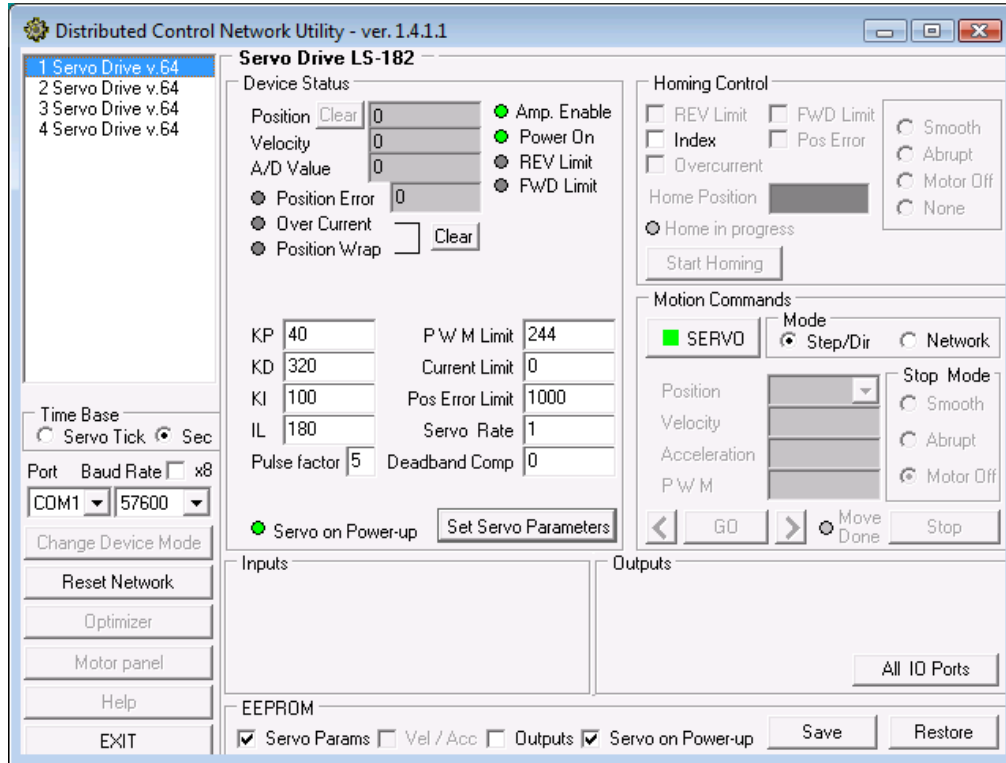

If instead you get a screen that looks like this:

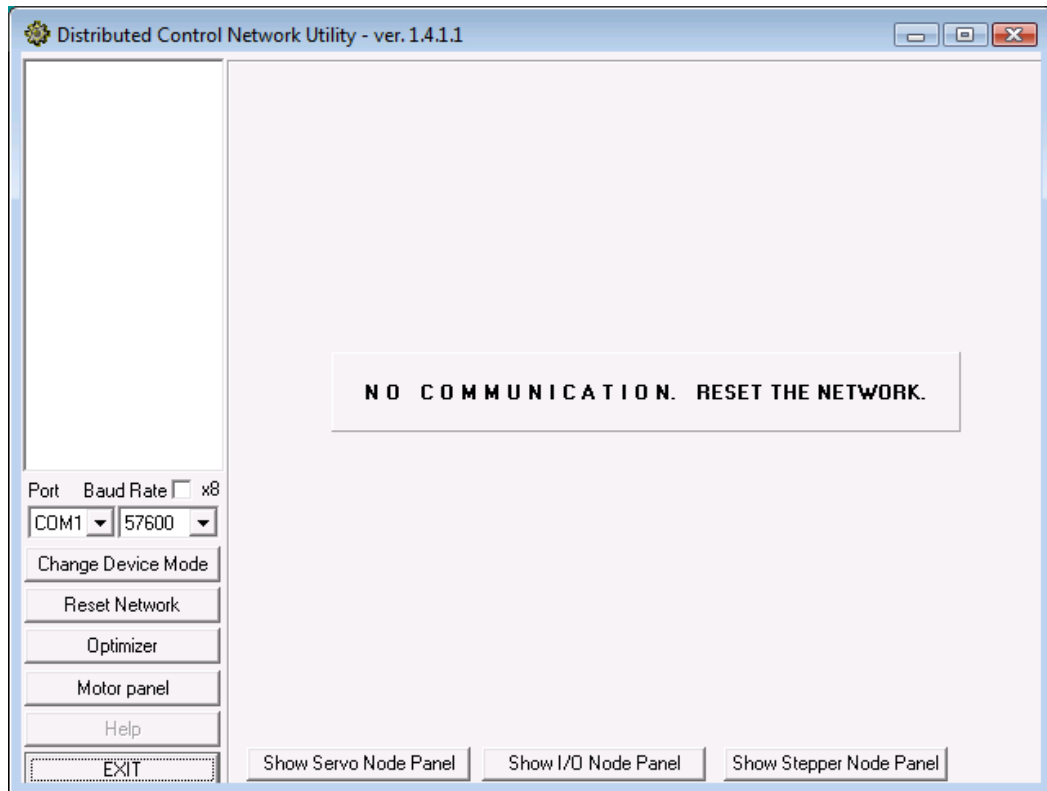

Then you need to check your Com Port settings and your baud rate (lower left of screen), check your cabling to make sure you have a good connection between your Com Port on the PC and the DB-9 Connector on the Servo Box. Once this all has been verified, choose the Reset Network button.

The upper left corner of the screen shows a list of the drive modules that you have:

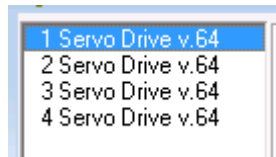

To change the servo parameters for a particular drive

1. Choose that drive from the module list.
2. Change the servo parameters you need to change for the drive. (See Servo Parameters in Appendix.)
3. Turn the servo off by choosing the Servo button in the Motion Commands area of the window. When the servo is on it will have a little green square in the button, when it is off the square will be gray.
4. Choose the Set Servo Parameters button. This will set the servo parameters in the drive, but they will be lost when you turn the power off to the servo unit.

5. To permanently save the servo parameters, make sure the servo params check box is checked in the EEPROM section of the window and choose the Save button with your left mouse button. If you right mouse click on the Save button, you can save the parameters to a file on your computer also. The default extension is .led.
6. You can also load servo parameters from a .led file by clicking Restore with the right mouse button, and then clicking Set Servo Parameters and the Save Button.
7. Repeat the above for all of the drive modules that you have.
8. Turn the unit off and disconnect the serial cable. It is now ready to be used with the new settings.

Optimizing your Servo Settings:

There is also a very useful feature that will help you automatically tune your motors while they are connected to your system. This can be done using the Optimizer button on the left side of the screen. Please note that the optimizer is an automated program that will go through an algorithm to find a local optimum for servo values. In many cases, this local optimum may not be the best values for your machine. Therefore, the optimizer is best used by watching your machine while it runs and writing down the parameters that look smooth and have a low position error. When the optimizer is finished, you then have the option of using the parameters that it found, or the ones that you found to be best during the test. You also have the option of using the optimizer to view the physical effects of servo parameters that you enter manually.

To try the optimizer, each drive must be taken out of STEP mode.

1. To take the servo box out of STEP mode simply click the radio button that says Network in the DCN software.
2. The unit is not in Step and Direction mode any more. You will only be able to use DCN to move the motors.
3. Make sure you position the each axis to the middle of their travel, as they will move back and forth during the tuning process. You can move the motors by typing in a position and velocity in the respective fields. They are in quadrature encoder counts and quadrature encoder counts/servo tick. $\text{Quadrature encoder counts} = \text{Encoder counts} \times 4$.
4. Open the DCN Utility and choose the Optimizer button.

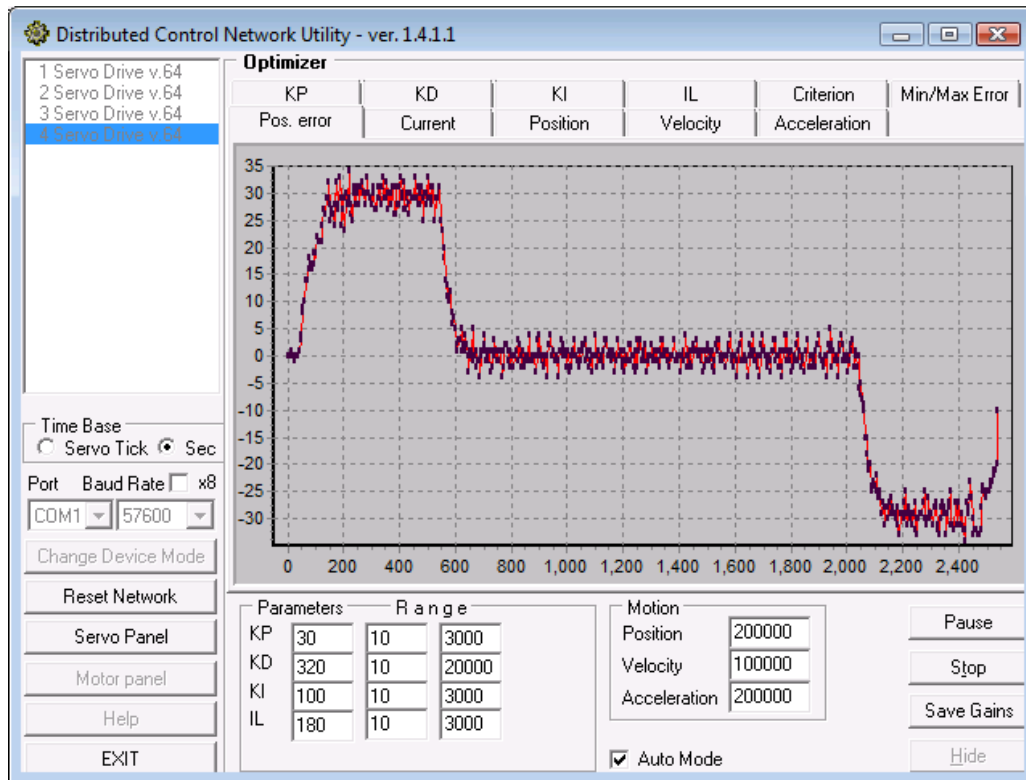

- The first column of Servo Parameters is a starting point for the optimizer, the second column is the low limit for each parameter and the third column is the high limit. Fill in amounts for each field. Sometimes, it is best to increase the upper ranges by 2 or 3 times their current values. Make sure that the Auto Mode box is checked. The optimizer will increment each of the parameters within the given range and find a local optimum value. If you want to test different parameters manually, make sure that Auto Mode is not checked.
- Choose a position, velocity and acceleration that seem appropriate for typical movement of your machine. The distance chosen should be just large enough for the motors to get up to speed and have room to decelerate to a stop. (Usually on the order of 0.25 to 2 inches of travel on your machine. (Remember, the distance is based on quadrature encoder counts and is independent of the encoder divisor).
- Hit the Start button and let the system run for a few minutes until it stabilizes on a set of servo parameters. You can view the position error (shown above) as it is doing the test. The criterion is to minimize the position error. When it has reached a stable value hit the Stop button.
- Save the new servo parameters (if you choose) by hitting the Save Gains button. You can exit the Optimizer by hitting the Hide button. (Make sure you follow the directions on saving the servo parameters above).
- Repeat the above process for each axis.
- Once you have finished you need to set the reset the module or reset the network to place the unit back into step and direction mode.
- You will now be able to use the system with Techno.

10. Motor Wiring:

The motor connectors contain all of the drive and encoder signals going out to the motors. The motors can be either brush or brushless and the encoder signals can be either differential or single ended. See the Appendix with the Schematics at the end of this manual for details.

11. Power Board

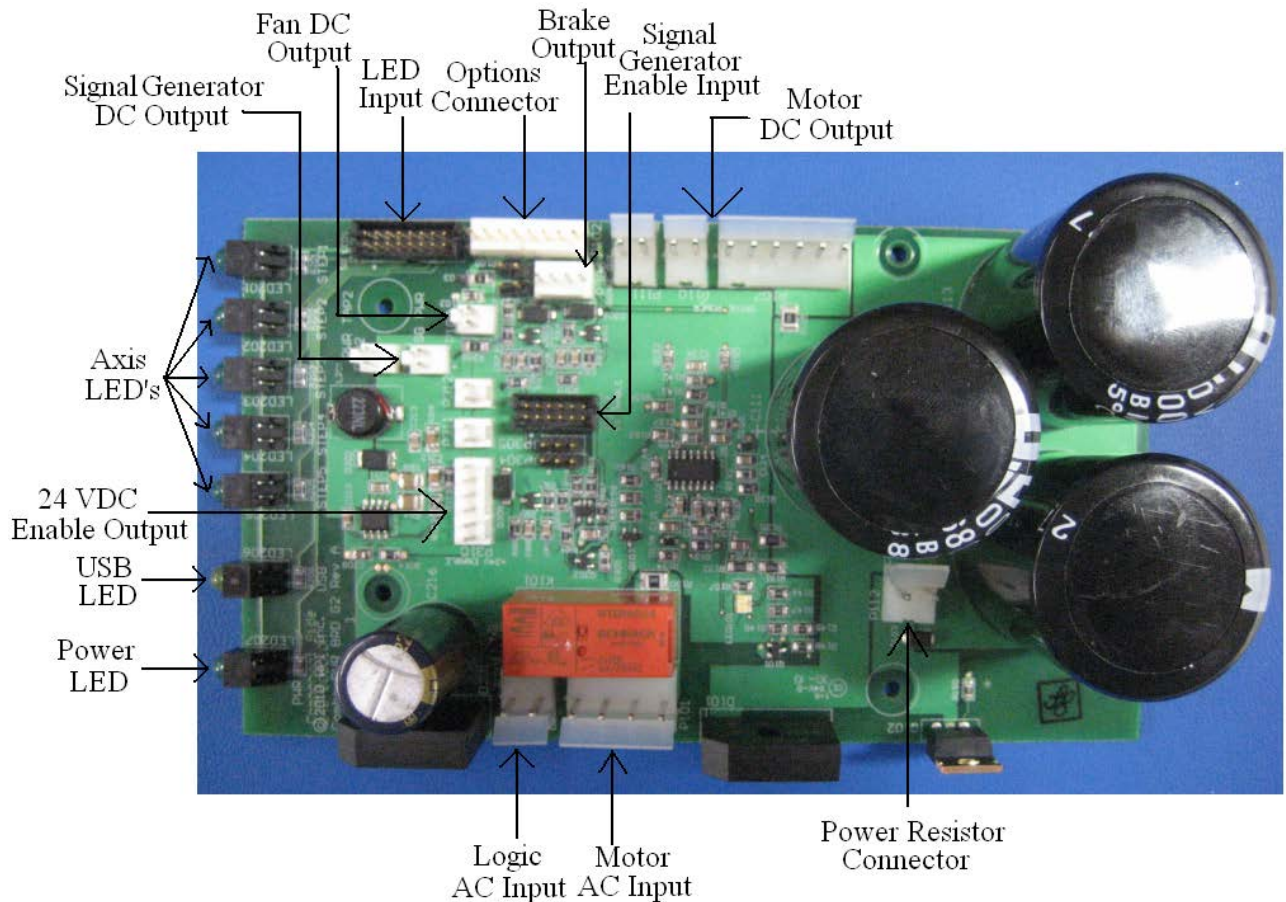

The function of the Power Board is to supply DC voltage to the drive modules as well as to the cooling fan and logic signals to the Signal Generator. The power enters the board in the form AC voltage from a transformer; the AC voltage is then converted to DC voltage. The Power Board also contains the indication LED's:

AXIS LED's 1, 2, 3, 4, 5 – Turns green when the respective axis is moving.

USB LED– Turns yellow when connected to the host PC USB port.

POWER LED– Turns green when the power switch is turned on.

LOGIC AC INPUT- This connector takes in the power from the transformer for the logic signals. The AC voltage from the transformer is then converted to a DC voltage to be used for logic signals. The two contacts are labeled as follows: L is the hot, N is the neutral.

MOTOR AC INPUT- This connector takes in the power from the transformer for the drive modules. The AC voltage from the transformer is then converted to a DC voltage of 40-80V, depending on the connection configuration, to be used for powering the drive

modules. The three contacts are labeled as follows: R is the reserve, L is the hot, N is the neutral. The reserve and the hot may be switched to vary the voltage. For example if R is red and L is purple the resulting DC voltage is approximately 67 VDC, where if R is purple and L is red the resulting DC voltage is approximately 80 VDC.

SIGNAL GENERATOR DC OUTPUT- This output sends a 9 VDC signal to power the Signal Generator. When viewing the power board in the configuration above the top contact of the signal generator DC output is positive and the bottom contact is negative.

FAN DC OUTPUT- This output sends a 24 VDC signal to power the fan for cooling the box. When viewing the power board in the configuration above the top contact of the fan DC output is positive and the bottom contact is negative.

BRAKE OUTPUT – This feature allows the use of a brake attached to a servo motor. When the drive modules have been enabled the brake is disengaged and the motor will be able to rotate freely. When the drive modules are disabled the brake is engaged and the shaft of the motor will be locked.

SIGNAL GENERATOR ENABLE INPUT. – This feature allows the brake to be turned on and off given the enable state of the Signal Generator. It also allows for using an enable signal greater than 5VDC.

MOTOR DC OUTPUT- This output sends a 40-80 VDC, depending on the connection configuration, DC signal to power the drive modules. Power for up to 5 individually powered drive modules. The contacts alternate positive and negative starting with positive on the contact nearest the large capacitor.

LED INPUT- This input receives logic signal from the signal generator in order to illuminate any of the 7 LED's indicating axis movement, power or USB connectivity. The contact connections for the LED input are as follows:

JP31 – STATUS LEDS

2 X 8 - 2MM SPACING

+5V	1	2	N/C
LED-DIR1	3	4	LED-STEP1
LED-DIR2	5	6	LED-STEP2
LED-DIR3	7	8	LED-STEP3
LED-DIR4	9	10	LED-STEP4
LED-DIR5	11	12	LED-STEP5
LED-AUX	13	14	LED-USB
GND	15	16	LED-PWR

POWER RESISTOR CONNECTOR – This connects the power resistor to the regeneration circuit. This circuit is used to prevent power spikes being fed back into the system by the motors being put into regeneration. A servo motor will be put into regeneration when deceleration a load, the inertia from the load will cause regeneration.

24 VDC ENABLE OUTPUT – This outputs a 24 VDC enable signal for drive modules requiring a 24 VDC enable signal as opposed to the standard 5 VDC enable signal provided by the signal generator.

OPTIONS CONNECTOR – This connector provides access to the emergency stop circuit, reset circuit and 24 VDC output circuit. Pin 1 and pin 2 control emergency stop 1 and is only activated when jumper JP 102 has been removed. Pin 3 and pin 4 control emergency stop 2 and is only activated when jumper JP 103 has been removed. When the emergency stop circuit is opened power will cease to flow to the drive modules. Only until after the circuit is closed will the drive modules become reenergized. Pin 5 and pin 6 control a 24 VDC output signal. This signal is always on when power is being supplied to the power board. Pin 7 and pin 8 control the reset circuit and is only activated when jumper JP TBD has been removed. When the reset circuit has been activated by removing the reset jumper the reset must be triggered on power up as well as after an emergency stop has been triggered, just releasing the emergency stop will not reenergize the drive modules.

12. Support:

Techno CNC Systems Office

29 Trade Zone Drive

Ronkonkoma, NY 11779

(631) 648-7481

(631) 983-4701 Fax

support@technocnc.com - e-mail

13. Appendix

Servo Parameters

The Servo Parameters panel allows the user to modify the eight servo control parameters, or gains. The "Set Servo Parameters" button will apply the gains to the selected controller. Here is a brief explanation of the servo algorithm and the associated parameters:

PID Servo Control

In general, in position or velocity mode, the motor is controlled by a servo loop which once every servo tick (1953 times/sec) looks at the current position of the motor, compares it to where the motor should be, and then uses a "control filter" to calculate an output which will cause the difference in positions, or the "position error" to become smaller. Two sets of parameters will govern the motion of the motor: the desired trajectory parameters (goal position, velocity, acceleration) which are described in the next section, and the control filter parameters discussed here.

The control filter is a "proportional-integral-derivative", or PID filter. The output to the motor amplifier is the sum of three components: one proportional to the position error providing most of the error correction, one proportional the *change* in the position error which provides a stabilizing damping effect, and one proportional to the accumulated position error which helps to cancel out any long-term error, or "steady state error".

The PID control filter, operating on the command position and the actual position each servo tick, produces an output calculated as follows:

$$\text{output} = K_p(\text{pos_error}) - K_d(\text{pos_error} - \text{prev_pos_error}) + K_i(\text{integral_error})$$

The term `pos_error` is simply the current command position minus the actual position. The `prev_pos_error` is the position error from the previous servo tick. `Kp`, `Ki` and `Kd` are the servo gains which will be programmed to optimize performance for your particular motor.

The `integral_error` is the running sum of `pos_error` divided by 256. To keep from growing a potentially huge `integral_error`, the running sum is bounded by a user specified integration limit. (Note that some other controllers will bound the value of the `integral_error`, but leave the actual running sum to grow unbounded, causing greater integral error windup.) By temporarily setting the integration limit to 0, the user can zero out the accumulated running sum.

The actual PWM output value (0-255) and direction bit are given by:

$$\text{PWM} = \min(\text{abs}(\text{output}/256), \text{output_limit}) - \text{current_limit_adjustment}$$
$$\text{Dir} = 0 \text{ if } \text{output} > 0, \text{ Dir} = 1 \text{ if } \text{output} < 0$$

First note that the scaled PWM output is limited by a user defined `output_limit`. For example, if you are using a 12v motor powered by 24v, you would want to set the `output_limit` to $255/2$, or

127. Also note that the final PWM value is reduced by a `current_limit_adjustment`. Under normal operation, `current_limit_adustment = 0`. If the motor current, as indicated by the A/D value, exceeds a user specified limit, `current_limit_adjustment` is incremented by 1 each servo tick, up to a maximum value

of $\min(\text{abs}(\text{output}/256), \text{output_limit})$. If the motor current is below the specified limit, `current_limit_adjustment` is decremented by 1, down to a minimum value of zero. This incremental adjustment is used rather than a proportional adjustment due to the non-linearity of many current sensing schemes, and in fact can be used with external amplifiers which provide only a binary current threshold value.

The PWM signal is a 19.53 KHz square wave of varying duty cycle with a PWM value of 255 corresponding to 100% and a value of 0 corresponding to 0%.

One last control parameter is the user specified position error limit. If $\text{abs}(\text{pos_error})$ becomes larger than this limit, the position servo will be disabled. This is useful for disabling the servo automatically upon a collision or stall condition. (This condition can also be used for homing the motor by intentionally running it up against a limit stop.)

Selection of the optimal PID control parameters can be done analytically, but more typically, they are chosen through experimentation. As a first cut, the following procedure may be used:

1. First set the position gain, K_p , and the integral gain, K_i , to 0. Keep increasing the derivative gain, K_d , until the motor starts to hum, and then back off a little bit. The motor shaft should feel more sluggish as the value for K_d is increased.
2. With K_d set at this maximal value, start increasing K_p and commanding test motions until the motor starts to overshoot the goal, then back off a little. Test motions should be small motions with very large acceleration and velocity. This will cause the trapezoidal profiling to jump to goal position in a single tick, giving the true step response of the motor.
3. Depending on the dynamics of your system, the motor may have a steady state error with K_p and K_d set as above. If this is the case, first set a value for IL of 16000 and then start increasing the value of K_i until the steady state error is reduced to an acceptable level within an acceptable time. Increasing K_i will typically introduce some overshoot in the position. The best value for K_p will be some compromise between overshoot and settling time.
4. Finally, reduce the value of IL to the minimum value which will still cancel out any steady state error.

The default (and maximum) servo rate is approximately 2 KHz (1.953 KHz, to be more exact). For systems with a combination of a large inertia, little inherent damping and limited encoder resolution, it may be difficult to get sufficient damping at low speeds because the digitization noise with very large values of K_d will cause the servo to hum or vibrate. Fortunately, such systems typically have a rather slow response and the servo rate can be decreased considerably. For example, switching from 2 KHz to 200 Hz will allow you to achieve the same level of damping with a value of $K_d/10$. The minimum

possible servo rate is 7.6 Hz.

In summary, we have a total of eight control filter parameters: Position Gain (Kp), Derivative Gain (Kd), Integral Gain (Ki), Integration Limit (IL), Output Limit (OL), Current Limit (CL), Position Error Limit (EL) and the Servo Rate

Parameter Ranges

KP, KI, KD

KP, KI, and KD are the primary control parameters used by the PID control filter. They must all be positive values in the range between 0 and 32,767.

Integration Limit (IL)

The integration limit limits the absolute value of the integral of the position error. The integration limit must be between 0 and 32,767. The limit value used internally is the limit value x 256. Limiting the integration term is useful for preventing huge sums from accumulating in that case of a locked rotor. Temporarily setting this value to zero can be used to zero out any accumulated integral error term.

Encoder Divisor

The Encoder Divisor divides the effective resolution of the encoder. This is especially useful if you want to get more speed out of your motor in exchange for increased encoder resolution. For example, if you have a 1000 line encoder which has 4000 quadrature counts per revolution, and you have an encoder divisor of 5, then your effective resolution would be 800 quadrature counts per revolution. The encoder divisor in DCN must match the encoder divisor in Techno CNC.

PWM Limit

The PWM limit sets the maximum PWM output value. If the control algorithm produces a larger value, the actual value will be clipped to the PWM limit value. The PWM limit must be between 0 and 255.

Current Limit

A/D value and CCL (continuous current limit parameter of Set Gain command) may be used for current limit control. A/D value is proportional to the motor current. CCL is compared each servo tick with A/D value. If the A/D input is connected to a voltage signal proportional to the motor current, the current limit can be used to adjust the PWM output to prevent the motor current from

exceeding the limit. If a current limit between 1 and 127 is used, the PWM output will be reduced if the A/D value exceeds the current limit. The Over current flag will be set whenever an over current condition occurs. A current limit value of 0 effectively disables current limiting.

Position Error Limit

The position error limit is used to detect locked rotor conditions or other situations where the motor is not tracking as accurately as it should. If the absolute value of the position error ever becomes greater than the position error limit, the position servo will be disabled and the PWM output value will be set to 0. The position error flag will also be set. The position error limit is in units of quadrature encoder counts, and must be between 0 and 16,383. For example a 1000 line encoder will have 4000 quadrature encoder counts.

Servo Rate

The servo rate is a clock divisor, which determines the length of a servo tick. The servo tick time is equal to 0.512 milliseconds multiplied by the servo rate divisor value. This value must be between 1 and 255. In general, this value may be left at the default value of 1, but for systems with a large inertia and/or low encoder resolution, it may be desirable to increase the tick time to improve the servo's damping characteristics.

Deadband Compensation

Some amplifier/motor combinations will exhibit a deadband around a zero PWM output. That is, small PWM values will have no visible effect on driving the motor. While servoing, the deadband compensation value will be added to the magnitude of the PWM output, thus boosting the control signal into the active region outside the deadband. This has the gain settings for Axis 1 in your servo controller. You can change the gain settings using the following guidelines:

Servo Schematics

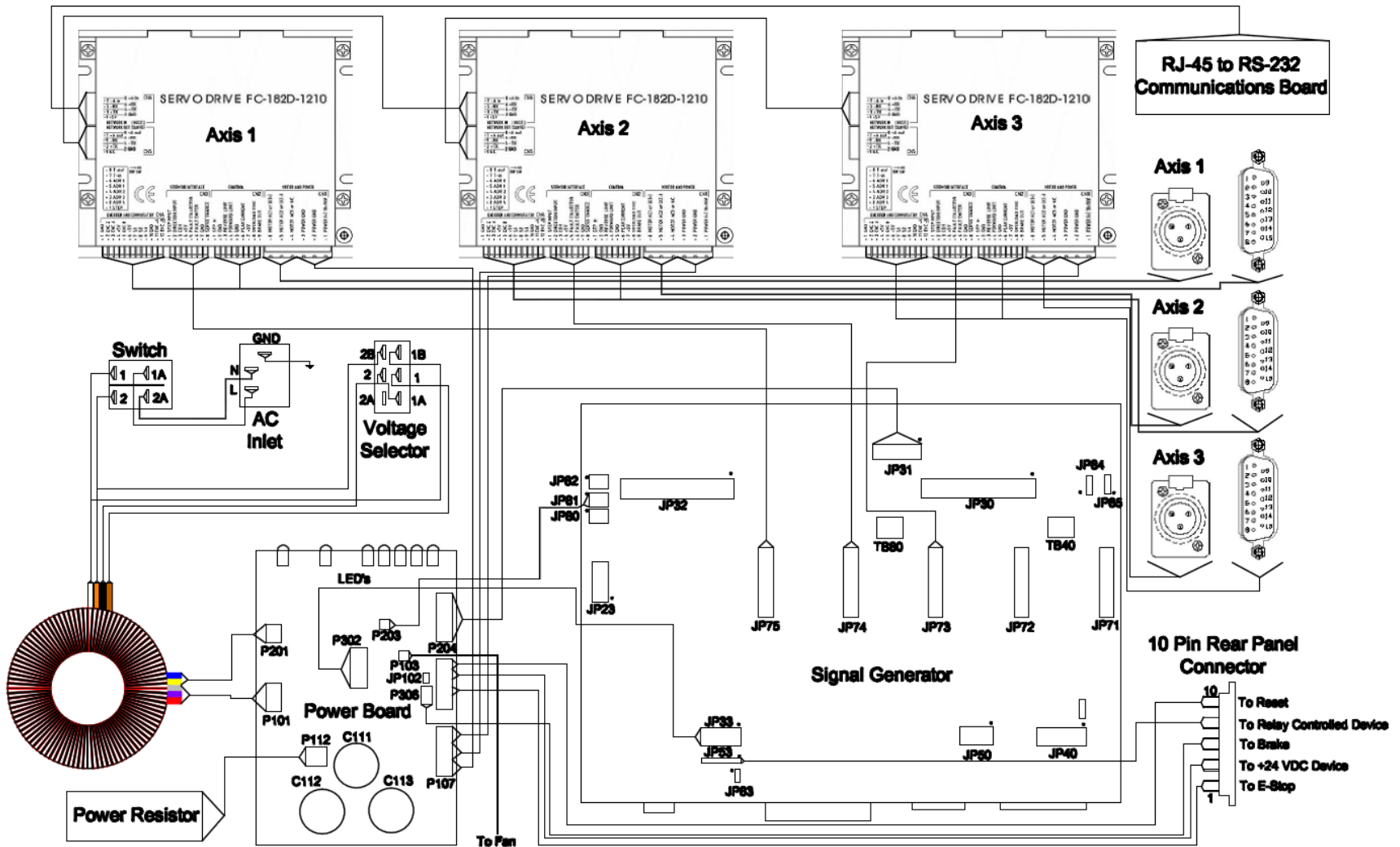

Internal Wiring From Motor Connector to Individual Servo Drive

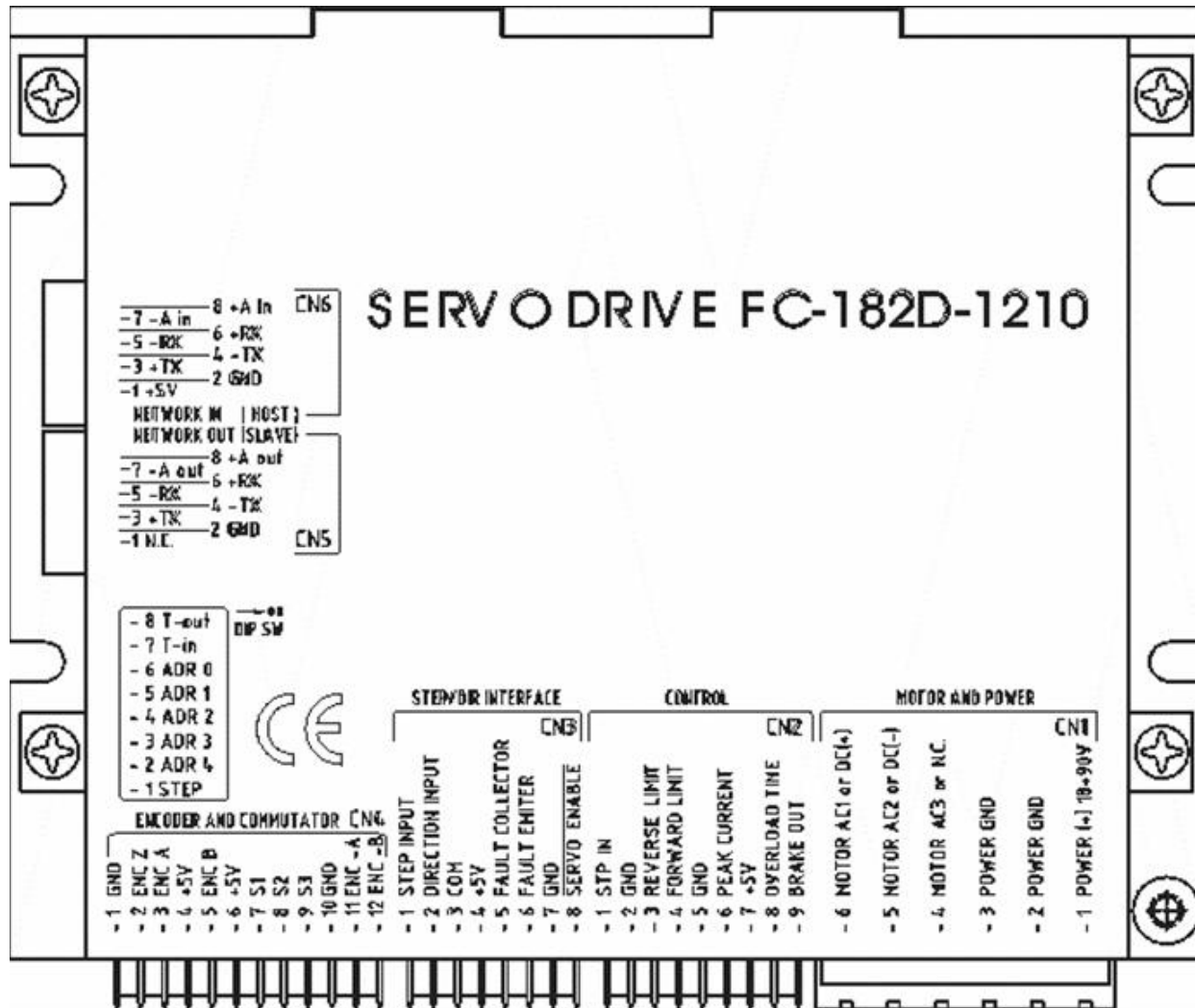

Wiring for MCG Automation Duty Connectors

Sensor Feedback Connector 24-26 gauge shielded cable	DB-15 Connector	Signal Name
A	NC	Thermostat
B	NC	Thermostat
C	1	S2 / Hall B
D	11	Enc Z / Index
E	NC	Enc Z~ / Index~
F	13	Enc A
G	5	Enc A~
H	10	Encoder GND
J	10	Sensor GND
K	2	Encoder VCC
L	2	Sensor VCC
M	9	S1 / Hall A
N	12	Enc B
P	4	Enc B~
R	3	S3 / Hall C
S, T, U, V	NC	
Cable Shield	Drain	Cable Shield
	6	No Connection
	7	NC or Lim(-)*
	8	NC or Lim GND*
	14	No Connection
	15	NC or Lim(+)*

Motor Connector 18 gauge shielded cable	3 Pin Motor Connector	Signal Name
1	1	AC1 / Phase R
2	2	AC2 / Phase S
3	3	AC3 / Phase T
4	Shield	Cable Shield

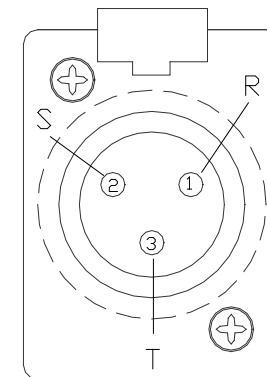
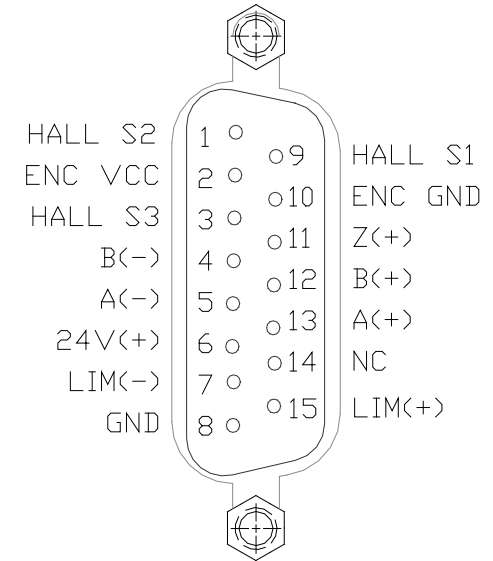

Connectors on Cables are DB15 Male and a Male Audio Connector (Neutrik NC3MX or equivalent).

* You can build an optional Limit Switch Cable connected to your DB15 Cable using pins 7, 8 and 15.

* For single ended encoder make sure switch 2 is in the off position on 182SE models.

Wiring for MCG Instrument Duty Motors

Encoder Lead Wire Connection 24-26 gauge shielded cable	DB-15 Connector	Signal Name
1 – Red	2	Encoder VCC
2 – Black	10	Encoder Ground
3 – White	13	Enc A
4 – Yellow	5	Enc A~
5 – Green	12	Enc B
6 – Blue	4	Enc B~
7 – Orange	11	Enc Z / Index
8 – Brown	NC	Enc Z~ / Index~
Cable Shield	Drain	Cable Shield
Sensor Lead Wire Connection		
White	9	S1 / Hall A
Orange	1	S2 / Hall B
Green	3	S3 / Hall C
Red	2	Sensor VCC
Black	10	Sensor GND
	6	No Connection
	7	NC or Lim(-)*
	8	NC or Lim GND*
	14	No Connection
	15	NC or Lim(+)*

Motor Lead Wire Connection 18 gauge	3 Pin Motor Connector	Signal Name
Red	1	AC1 / Phase R
White	2	AC2 / Phase S
Black	3	AC3 / Phase T
Cable Shield	Shield	Cable Shield

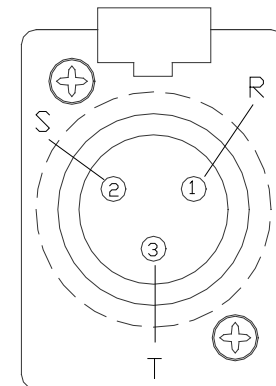
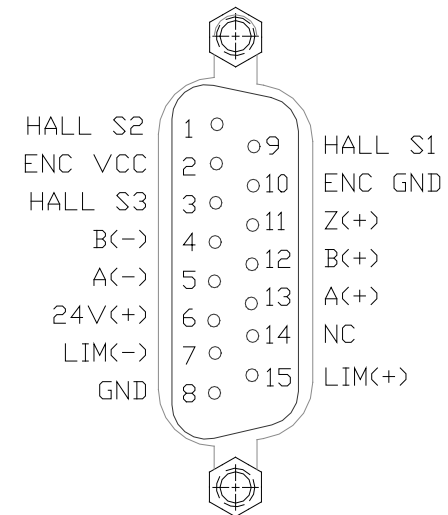

Connectors on Cables are DB15 Male and a Male Audio Connector (Neutrik NC3MX or equivalent).

* You can build an optional Limit Switch Cable connected to your DB15 Cable using pins 7, 8 and 15.

* For single ended encoder make sure switch 2 is in the off position on 182SE models.

Wiring for Brushless Servo Motors with Single Ended or Differential Encoder

DB-15 Connector	Signal Name
2	Encoder VCC
10	Encoder Ground
13	Enc A
5	Enc A~ NC for Single Ended
12	Enc B
4	Enc B~ NC for Single Ended
11	Enc Z / Index NC if Not Available
NC	Enc Z~ / Index~
Drain	Cable Shield
9	S1 / Hall A
1	S2 / Hall B
3	S3 / Hall C
2	Sensor VCC
10	Sensor GND
6	No Connection
7	NC or Lim(-)*
8	NC or Lim GND*
14	No Connection
15	NC or Lim(+)*

3 Pin Motor Connector	Signal Name
1	AC1 / Phase R
2	AC2 / Phase S
3	AC3 / Phase T
Shield	Cable Shield

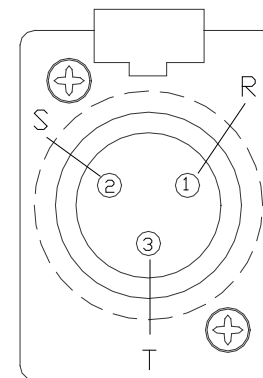
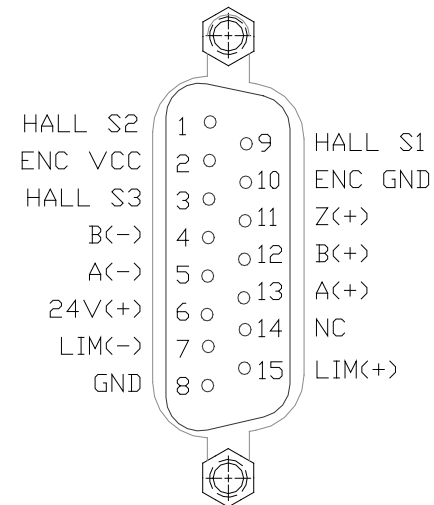

Connectors on Cables are DB15 Male and a Male Audio Connector (Neutrik NC3MX or equivalent).

* You can build an optional Limit Switch Cable connected to your DB15 Cable using pins 7, 8 and 15.

* For single ended encoder make sure switch 2 is in the off position on 182SE models.

Wiring for Brush-Type Servo Motors with Single Ended or Differential Encoder

DB-15 Connector	Signal Name
2	Encoder VCC
10	Encoder Ground
13	Enc A
5	Enc A~ NC for Single Ended
12	Enc B
4	Enc B~ NC for Single Ended
11	Enc Z / Index NC if Not Available
NC	Enc Z~ / Index~
Drain	Cable Shield
9	NC
1	NC
3	NC
6	No Connection
7	NC or Lim(-)*
8	NC or Lim GND*
14	No Connection
15	NC or Lim(+)*

3 Pin Motor Connector	Signal Name
1	DC+
2	DC-
3	NC
Shield	Cable Shield

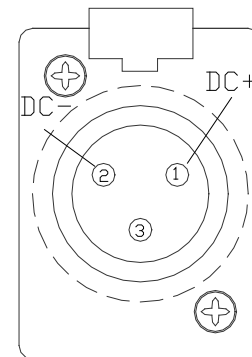
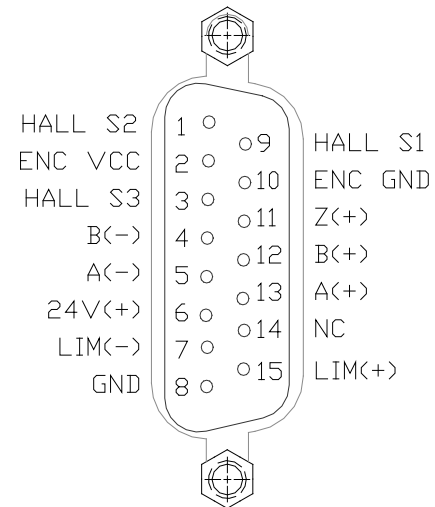

Connectors on Cables are DB15 Male and a Male Audio Connector (Neutrik NC3MX or equivalent).

* You can build an optional Limit Switch Cable connected to your DB15 Cable using pins 7, 8 and 15.

* For single ended encoder make sure switch 2 is in the off position on 182SE models.

Signal Generator Wiring Diagrams

Typical Output Line Circuit

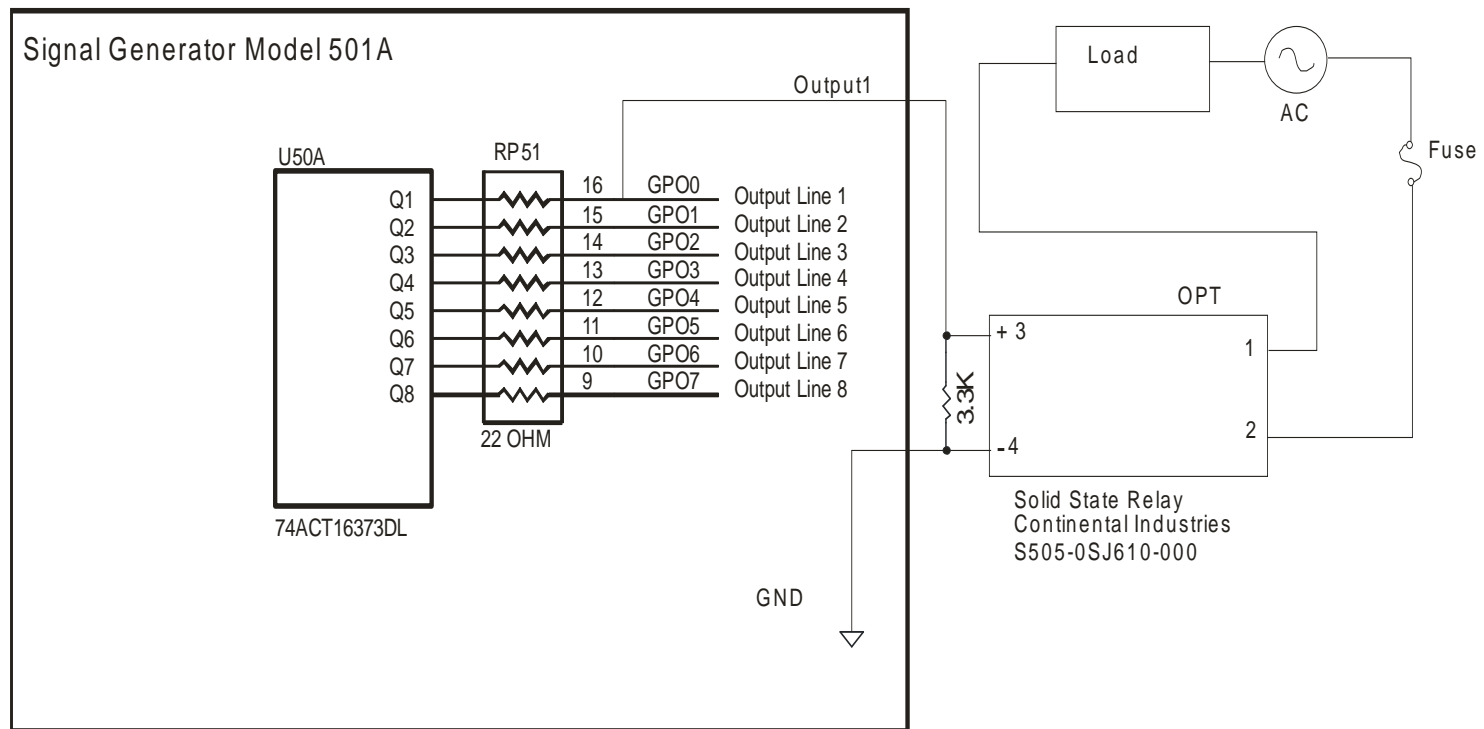

The above schematic shows a typical connection of one solid state relay controlled by output line 1 of the Signal Generator. A typical load would be a spindle, a vacuum, a laser, etc. In this example, the solid-state relay used is a Continental Industries model S505-0SJ610-000. It takes a 3 to 32VDC input and has an output of 24-330VAC.

Each of the output signals has a 22-ohm resistor in series with their outputs. This is to reduce any “ringing” at the transient switching points. Ground and 5V are provided on this connector for your convenience. The Techno Spindle On/Off Relay Box is wired as shown in the above schematic.

Typical Input Line Circuit – Internal Power

Signal Generator Model 501 A

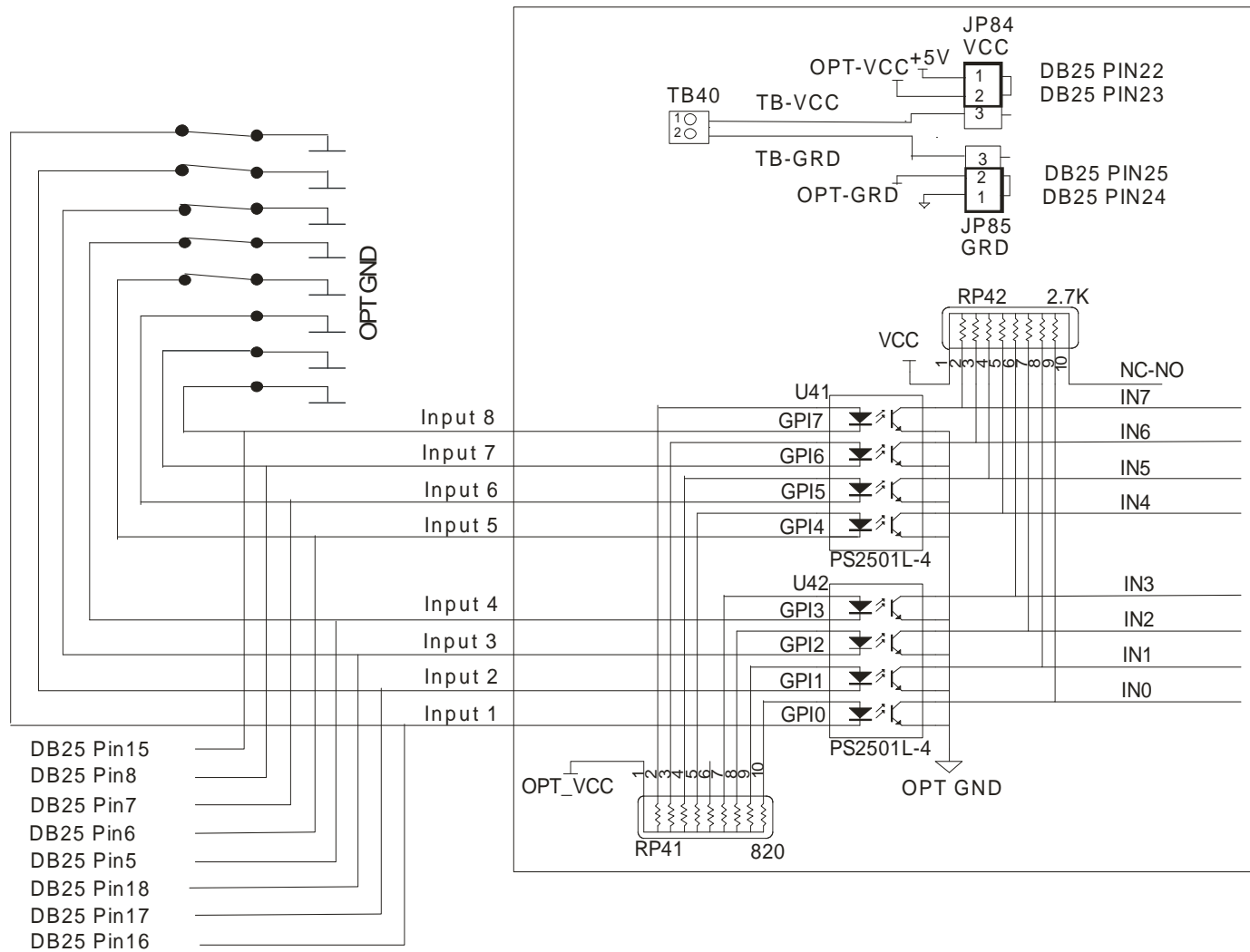

Typical Input Line Circuit – External Power

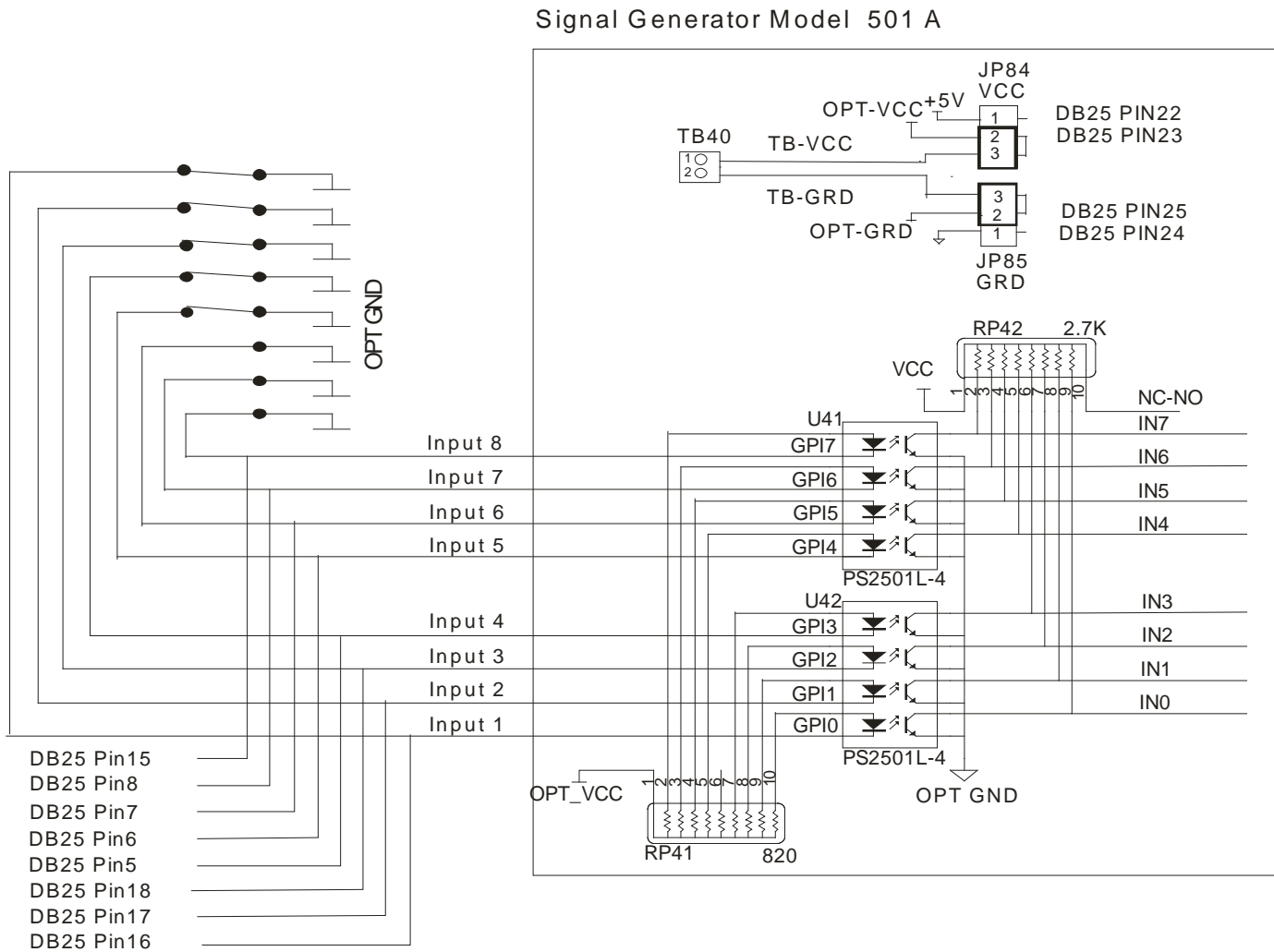

The above schematic shows a typical connection of 5 normally closed switches. These switches are connected between input lines 1-5 and ground. Lines 6-8 are connected directly to ground with jumper wires. All external connections shown are made through the Input connector on the back of the Signal Generator. This resistor pack (RP41) is socketed so that you can change the value if needed for your application.

The input lines are all optically isolated. In this example, JP84 and JP85 are shorted using the internal power to source the external side of the optical couplers. However, for the best isolation, JP84 and JP85 should be open, and power should be provided through pins 23 and 25 of the DB25 Motor Signal connector. Input lines 1-4 and 5- 8 are internally connected to pins 15-18 and 5-8 respectively of the DB25 Motor Signal connector.

Note that the Techno CNC limit switch kit has the same wiring as shown in this example.

Signal Generator Board Layout

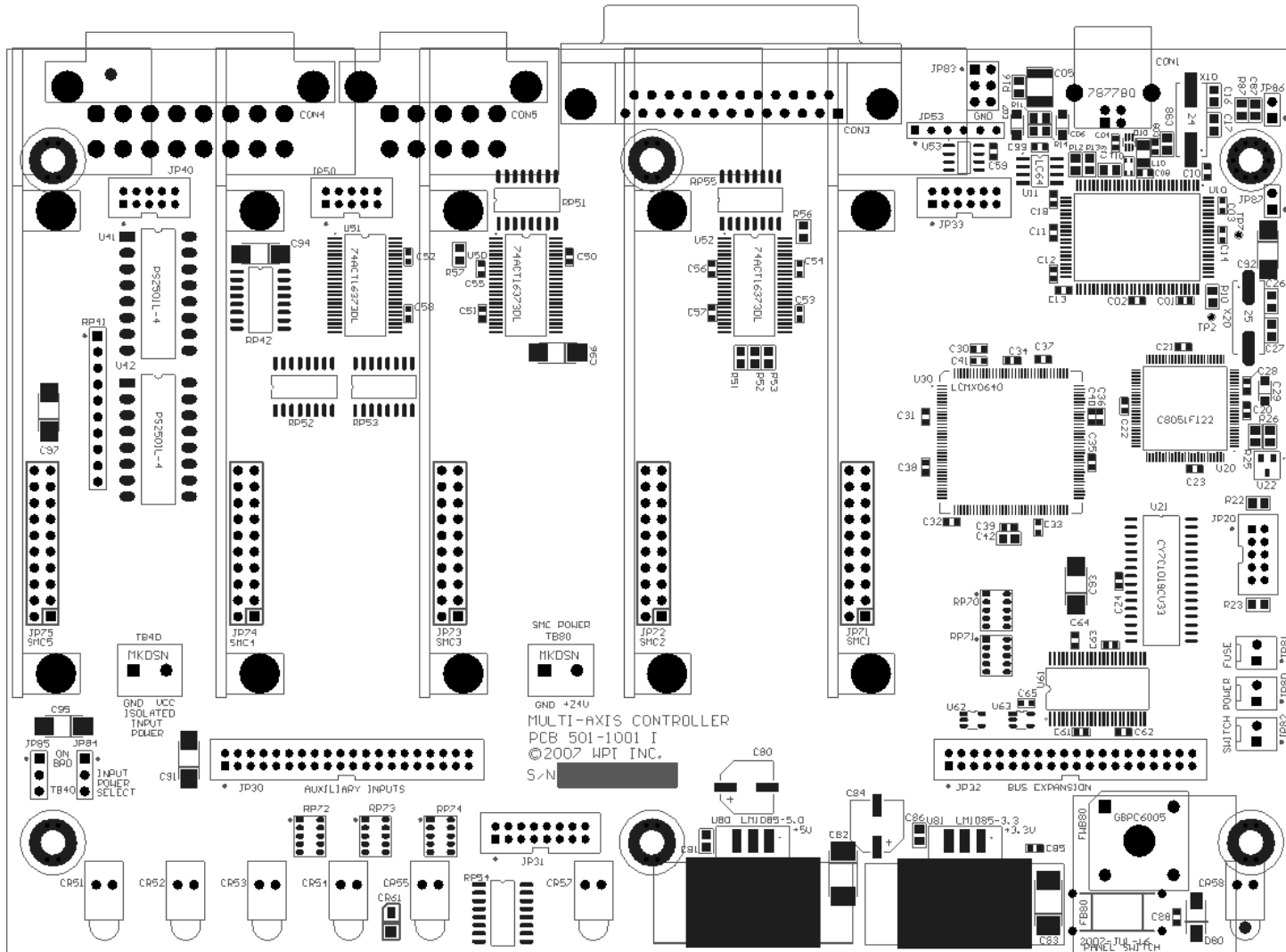

Connector Pin-Out Table

EXTERNAL CONNECTORS (RED)

CON1: STANDARD USB TYPE-A

CON3 – DB25F

GPO1	1	14	ENA
GPO2	2	15	GPI1
STEP5	3	16	GPI2
DIR5	4	17	GPI3
GPI5	5	18	GPI4
GPI6	6	19	DIR4
GPI7	7	20	DIR3
GPI8	8	21	DIR2
DIR1	9	22	VCC
STEP4	10	23	OPT-VCC
STEP3	11	24	GND
STEP2	12	25	OPT-GND
STEP1	13		SHIELD

CON4 - INPUTS

OPT-GND	1	9	GPI1
OPT-GND	2	10	GPI2
OPT-GND	3	11	GPI3
OPT-GND	4	12	GPI4
OPT-GND	5	13	GPI5
OPT-GND	6	14	GPI6
OPT-GND	7	15	GPI7
OPT-GND	8	16	GPI8

CON5 - OUTPUTS

GPO1	1	6	GPO2
GPO3	2	7	GPO4
GPO5	3	8	GPO6
GPO7	4	9	GPO8
VCC	5	10	GND

INTERNAL CONNECTORS (ORANGE)

PIN 1 OF ALL HEADERS IS INDICATED BY A SMALL WHITE DOT PRINTED ON THE PCB.

JP30 – AUXILIARY INPUTS

2 X 20 - 2MM SPACING

+3.3V	1	2	+3.3V
GPI32	3	4	GPI1
GPI31	5	6	GPI2
GPI30	7	8	GPI3
GPI29	9	10	GPI4
GPI28	11	12	GPI5
GPI27	13	14	GPI6
GPI26	15	16	GPI7
GPI25	17	18	GPI8
GND	19	20	GND
GPI24	21	22	GPI9
GPI23	23	24	GPI10
GPI22	25	26	GPI11
GPI21	27	28	GPI12
GPI20	29	30	GPI13
GPI19	31	32	GPI14
GPI18	33	34	GPI15
GPI17	35	36	GPI16
+3.3V	37	38	+3.3V
GND	39	40	GND

JP31 – STATUS LEDs

2 X 8 - 2MM SPACING

+5V	1	2	N/C
LED-DIR1	3	4	LED-STEP1
LED-DIR2	5	6	LED-STEP2
LED-DIR3	7	8	LED-STEP3
LED-DIR4	9	10	LED-STEP4
LED-DIR5	11	12	LED-STEP5
LED-AUX	13	14	LED-USB
GND	15	16	LED-PWR

INTERNAL CONNECTORS (ORANGE)

JP32 – BUS EXPANSION

2 X 20 - 2MM SPACING

+3.3V	1	2	GND
CS6	3	4	STATUS6
TXD2	5	6	FAULT6
RXD2	7	8	AUX1-STB
OUT-ENA	9	10	AUX2-STB
OUT2-STB	11	12	OUT1-STB
OUT4-STB	13	14	OUT3-STB
+5V	15	16	+5V
GND	17	18	GND
A0	19	20	A1
DATA1	21	22	DATA2
DATA3	23	24	DATA4
DATA8	25	26	DATA7
DATA6	27	28	DATA5
+7V	29	30	+7V
SPHOME	31	32	ENC CLK
+3.3V	33	34	ENC DIR
AGND	35	36	AV+
DAC2	37	38	DAC1
ADC1	39	40	AGND

JP33 – STEP & DIRECTION

2 X 6 - 2MM SPACING

STEP5	1	2	ENA
STEP4	3	4	DIR5
STEP3	5	6	DIR4
STEP2	7	8	DIR3
STEP1	9	10	DIR2
GND	11	12	DIR1

INTERNAL CONNECTORS (ORANGE)**JP40 – INPUT AUX HEADER**

2 X 8 - 2MM SPACING

GPI1	1	2	OPT-GND
GPI2	3	4	OPT-GND
GPI3	5	6	OPT-GND
GPI4	7	8	OPT-GND
GPI5	9	10	OPT-GND
GPI6	11	12	OPT-GND
GPI7	13	14	OPT-GND
GPI8	15	16	OPT-GND

JP50 – OUTPUT AUX HEADER

2 X 5 - 2MM SPACING

GPO2	1	2	GPO1
GPO4	3	4	GPO3
GPO6	5	6	GPO5
GPO8	7	8	GPO7
GND	9	10	VCC

JP53 – OUT 1&2 LOW SIDE DRIVER

1 X 6 - 2MM SPACING

+5V VCC	1
CLAMP for GPO2	2
GPO2 Low Side Driver	3
GPO1 Low Side Driver	4
CLAMP for GPO1	5
LOGIC GND	6

JP80 - REAR PANEL POWER**JP81 - REAR PANEL FUSE****JP82 - FRONT PANEL SWITCH****CONFIGURATION JUMPERS (BLUE)**

PIN 1 OF ALL JUMPERS IS INDICATED BY A SMALL WHITE DOT PRINTED ON THE PCB.

JP83: DB TO USB GROUND

ALWAYS LEAVE PIN 1 JUMPED TO PIN 2, PIN3 JUMPED TO PIN 4 AND PIN 5 JUMPED TO PIN 6 UNLESS DIRECTED OTHERWISE BY TECHNO TECH SUPPORT.

JP84/JP85: INPUT POWER SELECT

SHOULD BE JUMPED THE SAME WAY...

1-2: INPUTS DRIVEN BY ON-BOARD VCC

2-3: INPUTS BIASED BY VOLTAGE ON TB40

JP86: USB GROUND

SHOULD BE JUMPED TO PULL USB GROUND TO CHASSIS GROUND

JP87: CHASSIS GROUND

SHOULD BE JUMPED TO PULL INTERNAL SIGNAL GROUND OF THE SIGNAL GENERATOR TO CHASSIS GROUND.

TERMINAL BLOCKS (GREEN)**TB40: ISOLATED INPUT POWER**

VOLTAGE APPLIED HERE BIASES INPUTS IF JP84/JP85 ARE SHORTED PINS 2-3; DO NOT EXCEED 5V ON THIS TERMINAL UNLESS SPECIFICALLY ARRANGED WITH TECHNO TECH SUPPORT.

TB80: SMC POWER (24V)

APPLY 24 VDC HERE TO BIAS THE STEPPER MOTOR CONTROLLER BOARD(S) PLUGGED INTO SLOTS SMC1-SMC5

Power

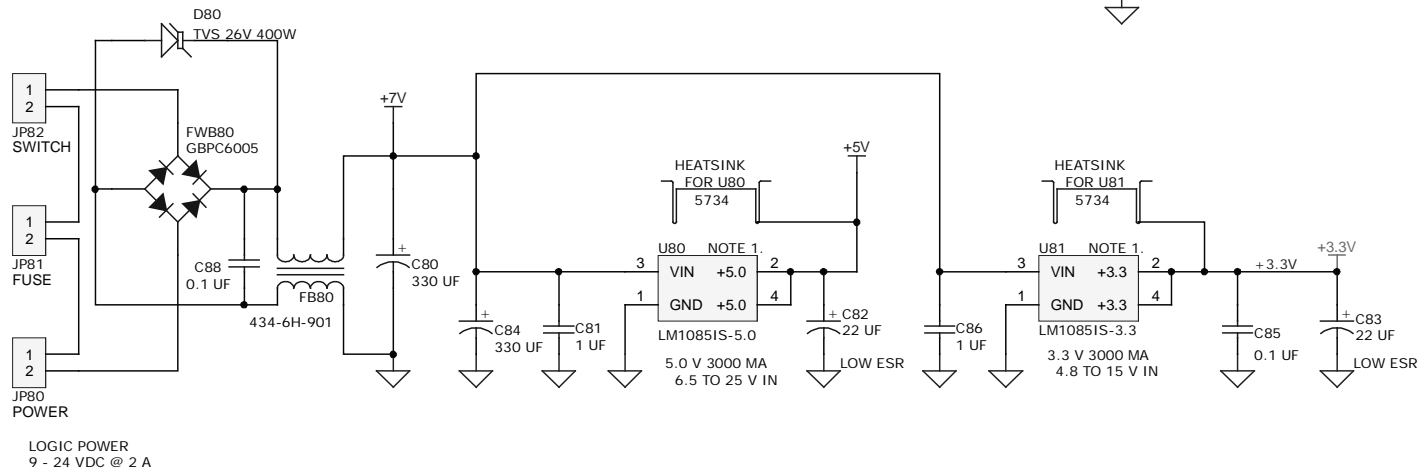
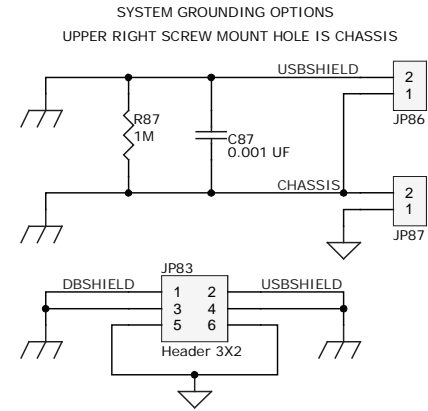
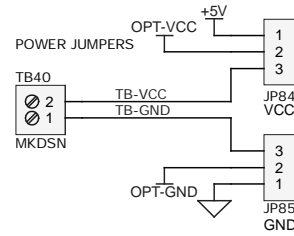
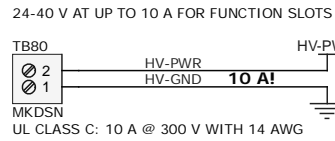

Outputs

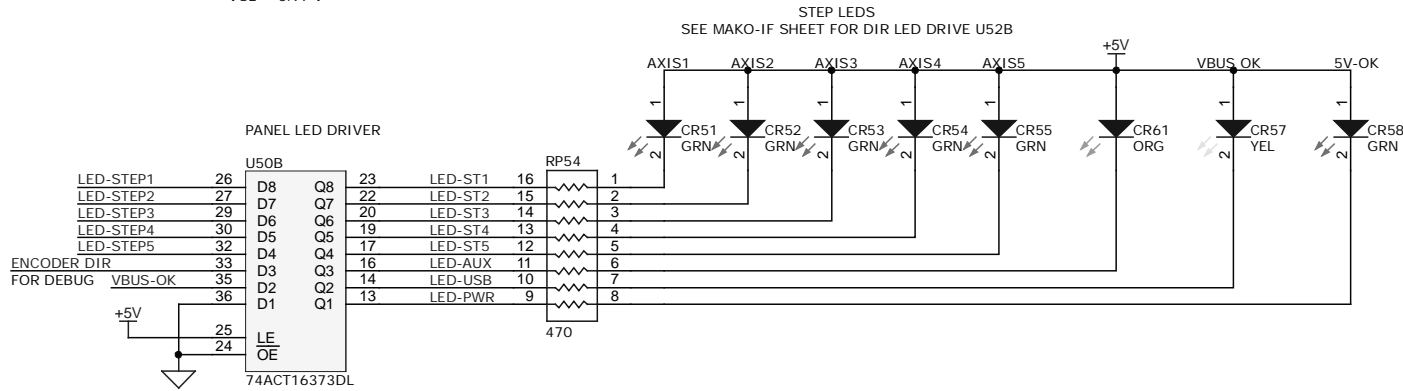
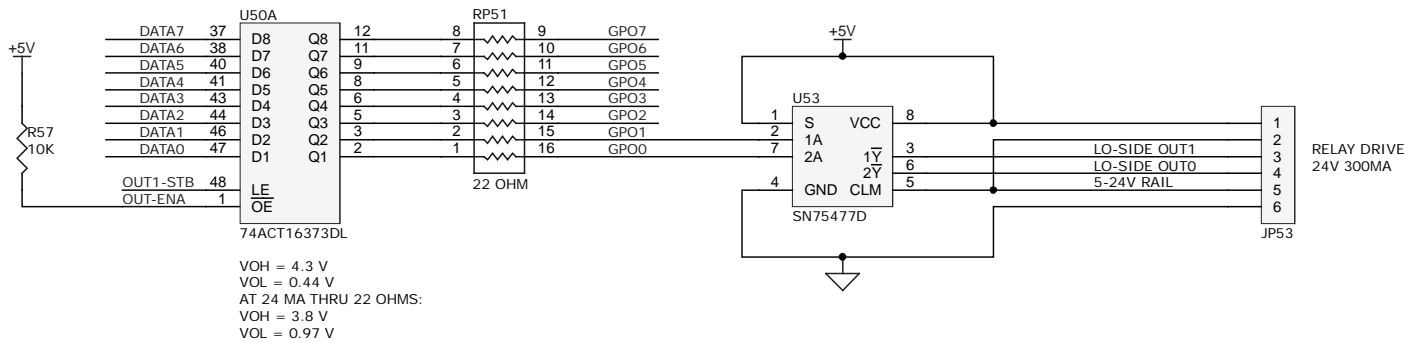

Inputs

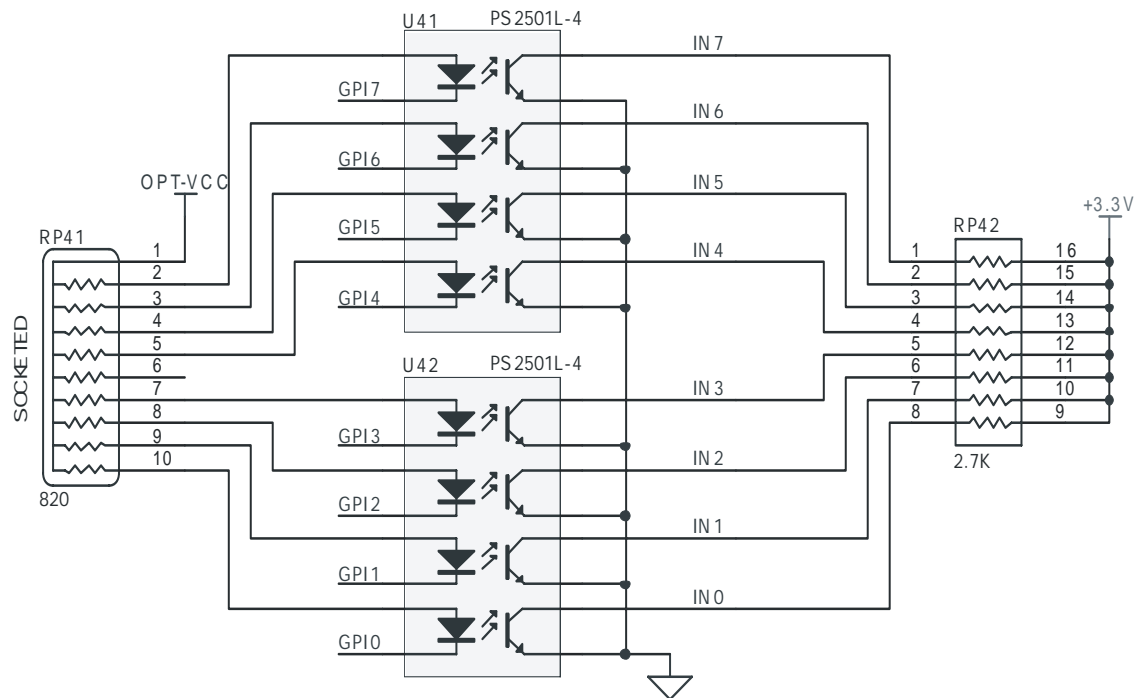

Connectors

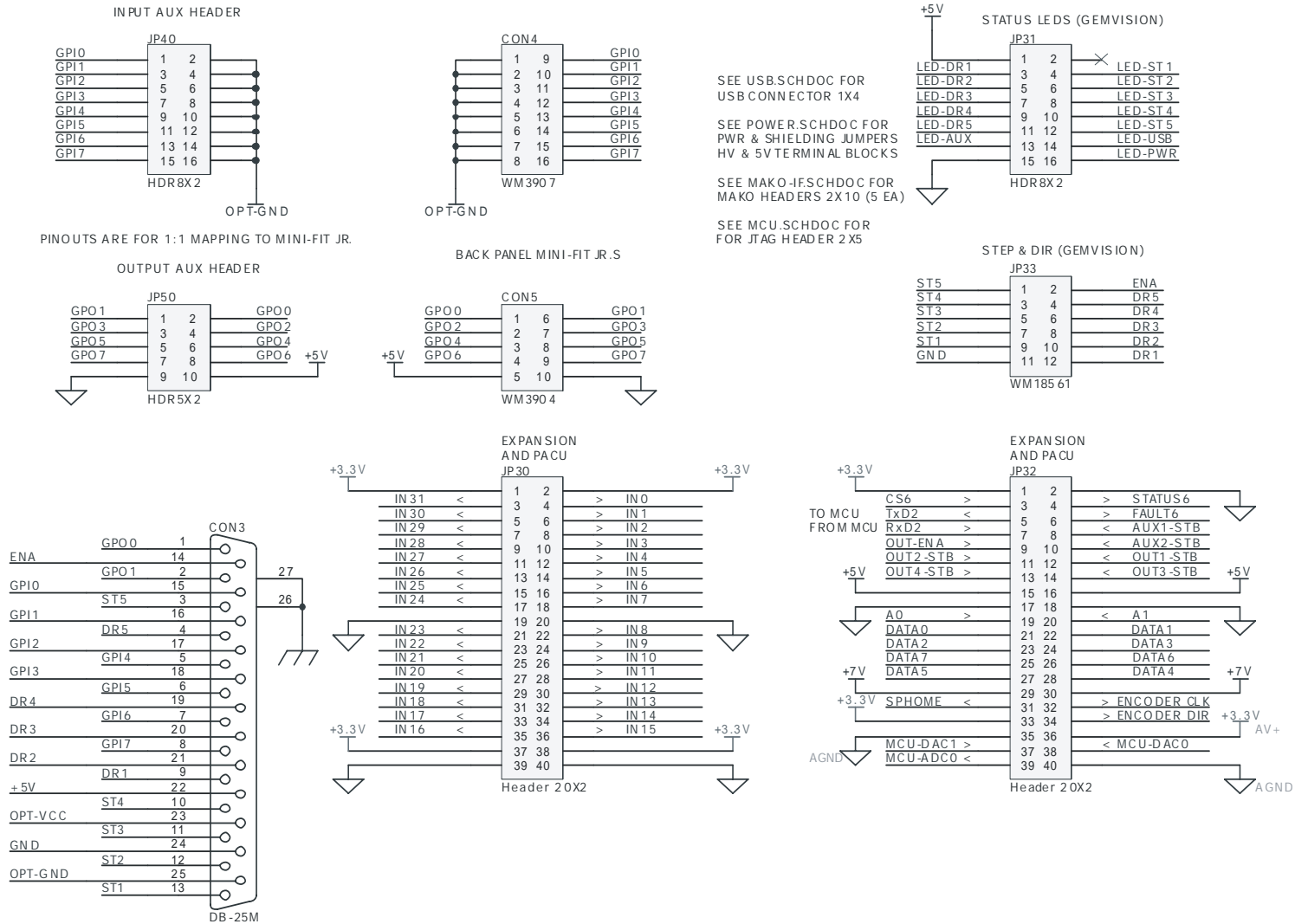

Axis Plug-In Interface

